

SRX900

Rigging Manual

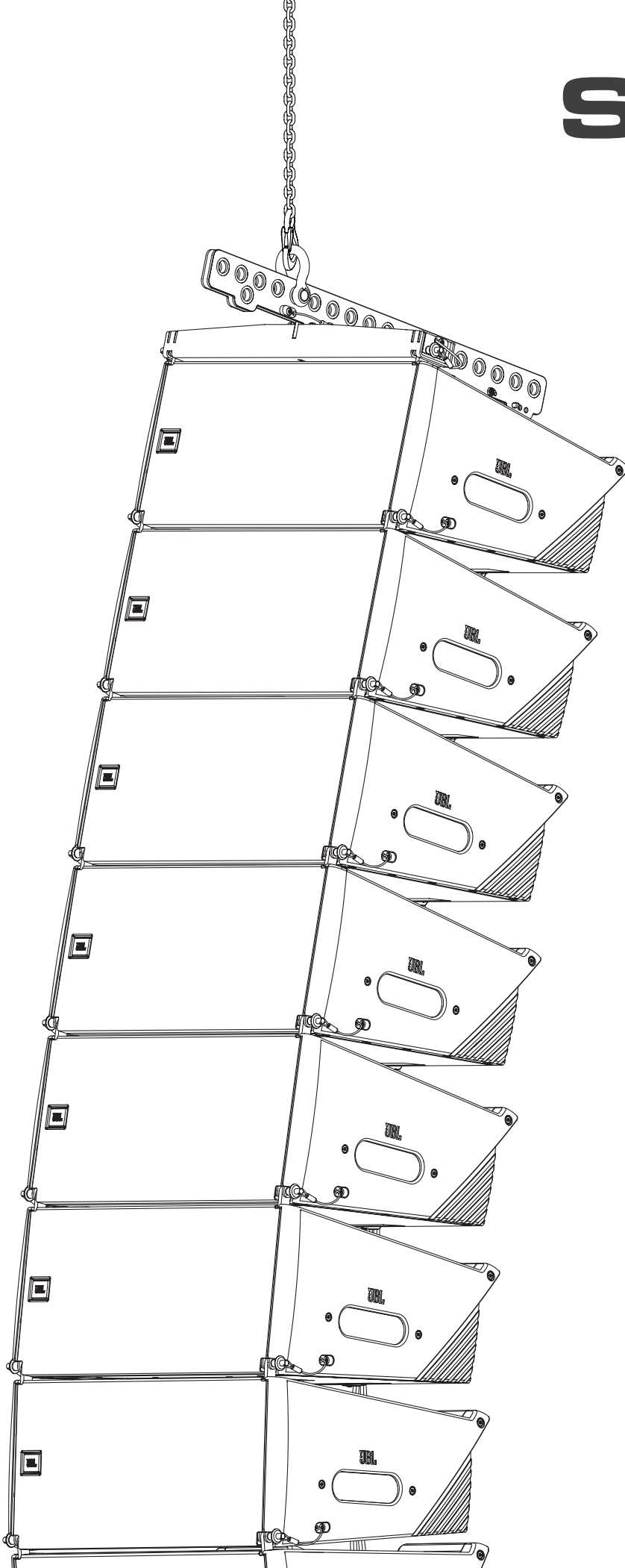

GENERAL INFORMATION

SRX900 Series - Rigging Manual

Part Number: 5152171-00

Version: D - EN

Distribution Date: January 30, 2025

Copyright © 2025 by Harman Professional, Inc.; all rights reserved

JBL PROFESSIONAL

8500 Balboa Blvd

Northridge, CA 91325

USA

TABLE OF CONTENTS

1 - DOCUMENT REVISION HISTORY 5

2 - SAFETY 6

 2.1 Safety Instructions 6

 2.2 General Hardware Information 6

 2.3 Attachment to Structures 6

 2.4 Important Safety Warning 6

 2.5 Are You New to Rigging? 7

 2.6 Inspection and Maintenance 7

 2.7 Symbols 8

 2.8 Resources and Documentation 8

3 - MECHANICAL LIMITS 9

 3.1 Suspended Array 9

 3.2 Ground-Stacked Arrays 9

4 - SYSTEM COMPONENTS 10

5 - SOFTWARE 13

 5.1 Venue Synthesis 13

 5.2 Suspended Arrays 14

 5.3 Ground-Stacked Arrays 15

6 - RIGGING SYSTEM OVERVIEW 16

 6.1 SRX900LA Rigging Closeup 16

 6.2 SRX900LA Angle Selection 17

 6.3 SRX900SF Rigging Closeup 18

 6.4 Deploying the SRX900SF Front Connection Bars 19

7 - TRANSPORTATION 20

 7.1 Installing Cabinets on the SRX900LA Case or VT 22

 7.2 Installing the SRX910LA VT-TOP 24

 7.3 Storing the SRX910LA VT 25

 7.4 Stacking the SRX910LA VT 26

 7.5 Installing the ACK1 27

 7.6 Installing SRX900 Subwoofers on a VT 28

8 - ARRAY FRAMES 29

 8.1 Array Frame Overview 29

 8.2 Attaching the Extension Bar to the Spreader Bar 30

 8.3 Array Frame Attachment Options 31

 8.4 Extension Bar Positioning 32

8.5 Installing the Laser Bracket. 33

9 - DEPLOYING ARRAYS 34

9.1 Set the Angles For the First Set Of Cabinets 34

9.2 Attaching the Array Frame 35

9.3 Suspend the First Stack 36

9.4 Attach the Next Stack 38

9.5 Repeat Until Completed. 40

10 - DISASSEMBLING AN ARRAY 41

10.1 Lower The Array and Remove the Stop Pins 41

10.2 Collapse the Array and Move the Pins to the Storage Position. 42

10.3 Repeat Steps to Disconnect the Next Four Cabinets 43

11 - DEPLOYING SUBWOOFER ARRAYS 45

11.1 Attaching the Array Frame to the First Subwoofer 45

11.2 Attaching Additional Subwoofers. 46

11.3 Suspending Mixed Arrays 48

11.4 De-Rigging Mixed Arrays 50

11.5 De-Rigging Flown Subwoofers 52

12 - PULL-BACK 54

12.1 Deploying Arrays Using a Pull-Back 54

12.2 When to Use a Pull-Back. 55

13 - BASE PLATES 56

13.1 Base Plate Overview 56

13.2 Base Plate Storage Position. 57

13.3 Angle Selection Plate 57

13.4 Assembling Ground-Stacked Arrays 58

13.5 Ground Stack Examples. 61

13.6 Attaching the Base Plate Onto a Structure 62

14 - POLE MOUNTING SRX906LA 63

14.1 Pole Mounting the SRX906LA BP 63

14.2 SRX906LA PM Overview. 65

14.3 SRX906LA PM Storage Position. 66

15 - CONTACT INFORMATION 67

1 - DOCUMENT REVISION HISTORY

VERSION	RELEASE DATE	CHANGES
Version A	May 10, 2022	<ul style="list-style-type: none">• Initial SRX900 Rigging Manual
Version B	June 27, 2022	<ul style="list-style-type: none">• Update SRX910LA AF Mechanical Limits• Updated technical support contact info
Version C	August 3, 2022	<ul style="list-style-type: none">• Added additional safety information to Section 11.7
Version D	January 30, 2025	<ul style="list-style-type: none">• Added Document Revision History• Replaced LAC-III software guidance with Venue Synthesis• Added SR915SF, SRX918SF, SRX915 VT, SRX918 VT, SRX928 VT, SRX906LA PM product guidance to manual• Updated tool requirements on page 27

2 - SAFETY

2.1 SAFETY INSTRUCTIONS

1. Read these instructions.
2. Keep these instructions.
3. Heed all warnings.
4. Follow all instructions.
5. Do not expose the product to direct rain or sea spray.
6. Clean only with a dry cloth.
7. Do not install near any heat sources such as radiators, heat registers, stoves, or other apparatus that produce heat.
8. Only use attachments/accessories specified by the manufacturer.
9. Use only with a cart, stand, tripod, bracket, or table specified by the manufacturer or sold with the apparatus. When a cart is used, use caution when moving the cart/apparatus combination to avoid injury from tip-over.
10. Refer all servicing to qualified service personnel. Servicing is required when the apparatus has been damaged in any way, such as if liquid has been spilled or objects have fallen into the apparatus, or if the apparatus has been exposed to rain or moisture, does not operate normally, or has been dropped.
11. Contact JBL Professional for advanced servicing issues.
12. **CAUTION - DO NOT PERFORM ANY SERVICING UNLESS YOU ARE QUALIFIED TO DO SO.**
13. Prolonged exposure to excessive SPL can cause hearing damage. The loudspeaker is easily capable of generating sound pressure levels (SPL) sufficient to cause permanent hearing damage to performers, production crew, and audience members. Caution should be taken to avoid prolonged exposure to SPL in excess of 90 dB.
14. Read this **Rigging Manual** before installation and use of the product.

2.2 GENERAL HARDWARE INFORMATION

Any hardware used in an overhead suspension application must be load rated for the intended use. Generally, this type of hardware is available from rigging supply houses, industrial supply catalogs, and specialized rigging distributors. Local hardware stores do not usually stock these products. Compliant hardware will be referenced with a working load limit (WLL) and a traceability code.

2.3 ATTACHMENT TO STRUCTURES

A licensed Professional Engineer must approve the placement and method of attachment to the structure prior to the installation of any overhead object. The following performance standards should be provided to the Professional Engineer for design purposes: Uniform Building Code as applicable, Municipal Building Code as applicable, and Seismic Code as applicable. The installation of the hardware and method of attachment must be carried out in the manner specified by the Professional Engineer. Improper installation may result in damage, injury, or death.

2.4 IMPORTANT SAFETY WARNING

The information in this section has been assembled from recognized engineering data and is intended for informational purposes only. None of the information in this section should be used without first obtaining competent advice with respect to applicability to a given

circumstance. None of the information presented herein is intended as a representation or warranty on the part of JBL. Anyone making use of this information assumes all liability arising from such use.

All information presented herein is based upon materials and practices common to North America and may not directly apply to other countries because of differing material dimensions, specifications, and/or local regulations. Users in other countries should consult with appropriate engineering and regulatory authorities for specific guidelines.

Correct use of all included hardware is required for secure system suspension. Careful calculations should always be performed to ensure that all components are used within their working load limits before the array is suspended. Never exceed the maximum recommended load ratings.

Before suspending any speaker system, always inspect all components (enclosure, rigging frames, pins, eye bolts, track fittings, etc.) for cracks, deformations, corrosion, or missing/loose/damaged parts that could reduce strength and safety of the array. Do not suspend the speaker until the proper corrective action has been taken. Use only load-rated hardware when suspending JBL suspendable loudspeaker models.

2.5 ARE YOU NEW TO RIGGING?

If you are new to rigging, you should:

- Know the rules for safe rigging.
- Attend a safe rigging seminar.
- Meet and establish a relationship with a licensed mechanical or structural engineer. Get in the habit of asking them questions instead of assuming their answers. Learn from what they tell you.
- Research and understand the codes, practices, and requirements of the venues where you intend to operate your sound system.

2.6 INSPECTION AND MAINTENANCE

Suspension systems are comprised of mechanical devices and, as such, require regular inspection and routine maintenance to ensure proper functionality. Before suspending or pole mounting any speaker system, always inspect all components (enclosure, suspension frames or brackets, pins, eyebolts, etc.) for cracks, deformations, corrosion, or missing/loose/damaged parts that could reduce strength and safety of the array. Do not suspend or pole mount a speaker until the proper corrective action has been taken.

Installed systems should be inspected at least once a year. The inspection must include a visual survey of all corners and load-bearing surfaces for signs of cracking, water damage, delamination, or any other condition that may decrease the strength of the loudspeaker enclosure.

Accessory suspension hardware provided with or for SRX900 systems must be inspected for fatigue at least once a year or as required by local ordinance. The inspection must include a visual survey of the material for signs of corrosion, bending, or any other condition that may decrease the strength of the fastener. Additionally, any eyebolts must be checked for possible spin-out of the enclosure.

For all other hardware and fittings, refer to the hardware manufacturer's inspection and maintenance guidelines for process.

JBL is not responsible for the application of its products for any purpose or the misuse of this information for any purpose. Furthermore, JBL is not responsible for the abuse of its products caused by avoiding compliance with inspection and maintenance procedures or any other abuse.

Prior to suspending the system, an expert, trained and experienced in suspending speaker systems, should inspect all parts and components.

2.7 SYMBOLS

The following symbols are used in this document:



CAUTION: This symbol gives notice of a potential risk of harm to the individual or the equipment. Instructions marked with this symbol must be strictly followed.



TIP: This symbol gives notice of helpful, relevant information about the topic.



INSTRUCTIONS: This symbol gives notice of instructions that must be followed for proper installation and use of the product.



TOOLS REQUIRED: This symbol gives notice of tools that must be used for proper installation and use of the product.



TIPPING HAZARD: This symbol gives notice of potential tip hazard. Use caution when moving the cart/apparatus combination to avoid injury from tip-over.

2.8 RESOURCES AND DOCUMENTATION

Several resources are available to SRX900 Series owners to illustrate proper and safe use of the equipment. Below is an overview of what is available and a brief description of each resource:

USER MANUAL: This document focuses on the electromechanical aspects of the system, including amplification, wiring, speaker pre-sets, tuning, and optimization. User manuals do not include information regarding rigging and suspension hardware.

RIGGING MANUAL: This document focuses on the mechanical aspects of the system, including step-by-step rigging instructions, accessory usage, mechanical limits, and safety instructions. All users must read this document.

SPECIFICATION SHEETS: These documents include detailed specifications for loudspeakers and accessories. Specifications include acoustical performance, material types, weight, and general mechanical information. Specification sheets are available for each SKU.

CUSTOMER DRAWINGS: This is a collection of files that include detailed drawings for each SKU. The collection consists of detailed dimensional 2D PDF/DXF documents and simplified 3D DXF models. Depending on the product, additional types of 3D files might be available for download at www.jblpro.com.

VIDEO TUTORIALS: Software and hardware video tutorials are available for watching on the JBL Professional [YouTube channel](#).

3 - MECHANICAL LIMITS

The SRX900 Series products and accessories comply with the 2006/42/EC Machinery Directive and have been designed following the guidelines of DGUV regulation 17 (BGV-C1) for a minimum safety factor of 4:1. Minimum safety factor requirements for suspended arrays are often set by local regulations. Use JBL Venue Synthesis software to check mechanical limits and ensure compliance with local regulations. ANSI Standard E1.8 (Entertainment Technology Loudspeaker Enclosures Intended for Overhead Suspension), Section 5.3.4, specifies a minimum safety factor of 5:1. If compliance with the ANSI standard is needed, make sure that the array design produces a minimum safety factor of 5:1.

3.1 SUSPENDED ARRAY

ACCESSORY	NOTES	SAFE LIMIT	MAXIMUM LIMIT
SRX906LA AF	SRX906LA Array with Array Frame	(14)	(16)
SRX906LA AF	SRX915SF Array with Array Frame	(5)	(8)
SRX900LA PB	SRX900LA Pull Back accessory used with SRX906LA	(9)	(16)
SRX910LA AF	SRX910LA Array with Array Frame	(13)	(16)
SRX910LA AF	SRX918SF Array with Array Frame	(5)	(8)
SRX900LA PB	SRX900LA Pull Back accessory used with SRX910LA	(9)	(16)

3.2 GROUND-STACKED ARRAYS

ACCESSORY	NOTES	SAFE LIMIT	MAXIMUM LIMIT
SRX906LA BP	Base Plate for ground stacking SRX906LA systems	(2)	(6)
SRX910LA BP	Base Plate for ground stacking SRX910LA systems	(2)	(4)
SRX906LA PM	Dedicated pole mount for SRX906LA Systems	(1)	(2)

TERMINOLOGY:

Safe Limit: The safe limit provides the number of cabinets that can be used in an array while maintaining a safety factor of 4:1 or higher. The safety factor of an array is determined by the number of cabinets, the array shape, and the overall array angle. An array constructed within the safe limit will always yield a safety factor greater than 4:1 regardless of array parameters and conditions. Ground-stacked arrays within the safe limit are stable under normal conditions. Designs exceeding the safe limit and up to the maximum limit are possible, but JBL Venue Synthesis software should be used to check mechanical safety for the given configuration.

Maximum Limit: Arrays larger than the maximum limit are not allowable under any conditions.

NOTES:

- Venue Synthesis allows for array designs with a minimum design factor of 4:1. Anything lower than that is not allowed.
- Safe and maximum limits are only applicable to the specified accessory (i.e. base plate or array frame). When several accessories are combined (for example, ground-stacked arrays with a base plate and subwoofers underneath), the design should always be evaluated and checked with Venue Synthesis.
- Safe and maximum limits for base plate accessories are specified for standalone use. Limits might differ when base plates are attached to subwoofers or other structures.



CAUTION: Limits for ground-stacked arrays always assume that the stacking surface (floor or stage) is flat. Do not deploy ground-stacked arrays on non-flat surfaces to avoid tipping hazards.

4 - SYSTEM COMPONENTS

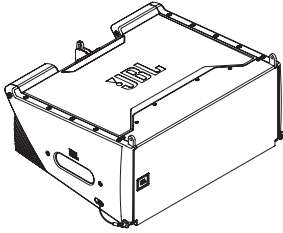

SRX906LA | Line Array Element

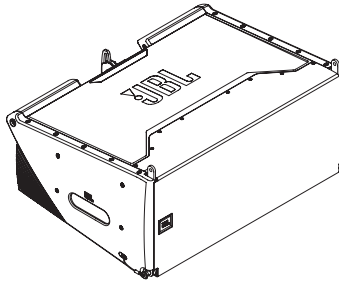

SRX910LA | Line Array Element

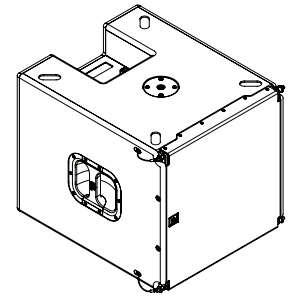

SRX915SF | Arrayable Subwoofer

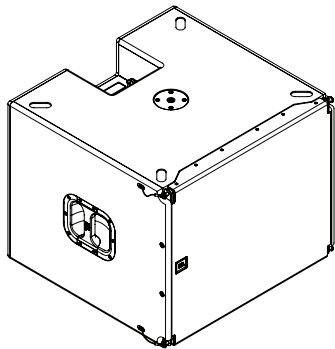

SRX918SF | Arrayable Subwoofer

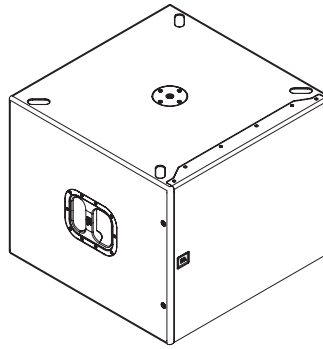

SRX918S | Subwoofer

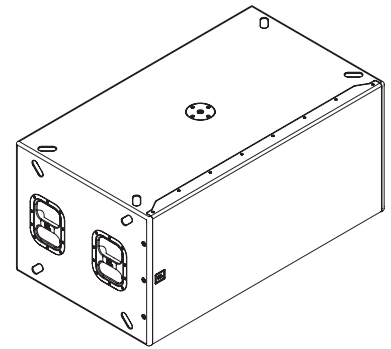

SRX928S | Subwoofer

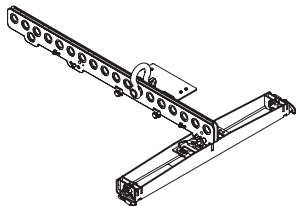

SRX906LA AF | Array Frame

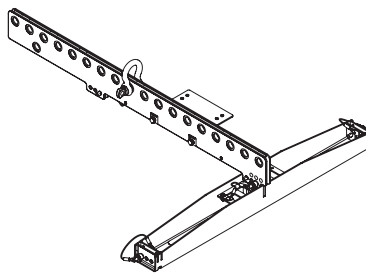

SRX910LA AF | Array Frame

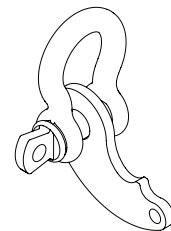

SRX900LA PB | Pull Back

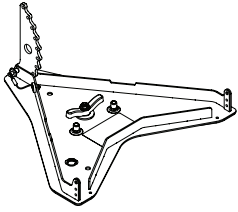

SRX906LA BP | Base Plate

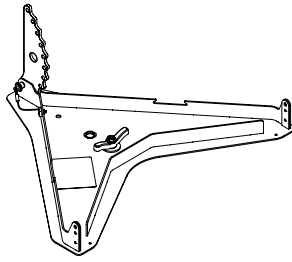

SRX910LA BP | Base Plate

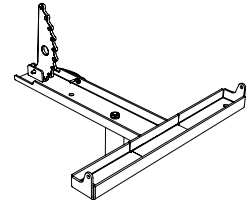

SRX906LA PM | Pole Mount

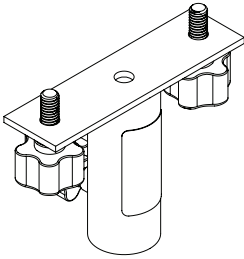

VTX PM | Pole Mount Adapter T-Style

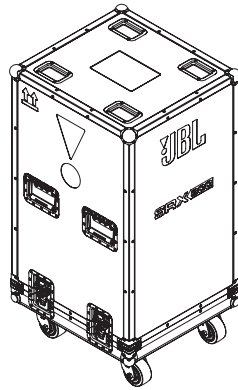

SRX906LA CASE

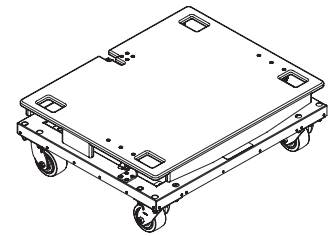

SRX910LA VT | Vertical Transport

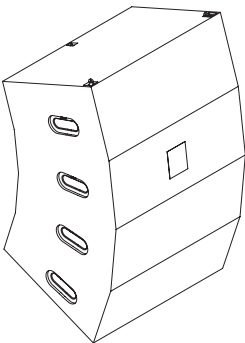

SRX910LA VT CVR

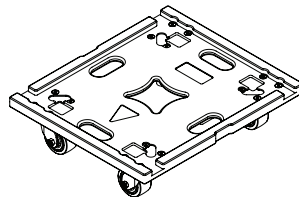

SRX915S VT | Vertical Transport

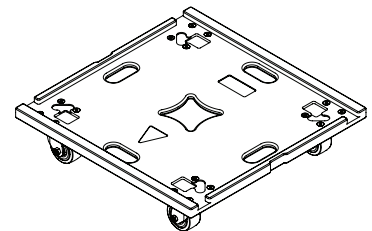

SRX918S VT | Vertical Transport

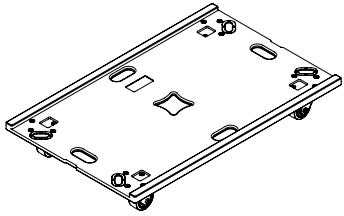

SRX928S VT | Vertical Transport

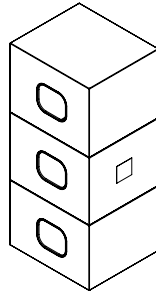

SRX915S VT CVR

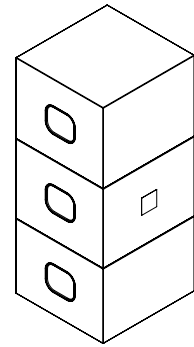

SRX918S VT CVR

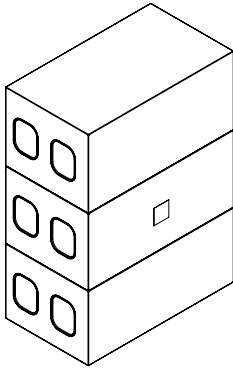

SRX928S VT CVR

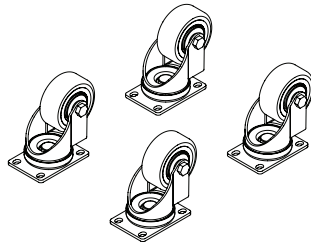

ACK1 | Accessory Caster Kit

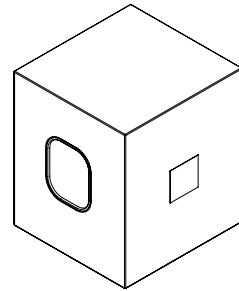

SRX915S CVR

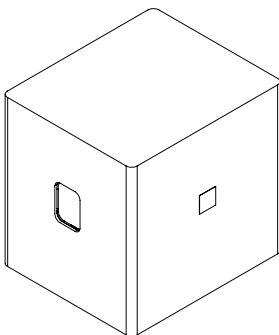

**SRX918S CVR
SRX918SF CVR**

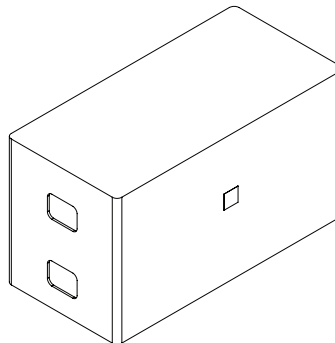

SRX928S CVR

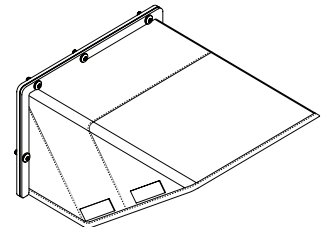

SRX900 RC | Rain Cover

5 - SOFTWARE

5.1 VENUE SYNTHESIS

Venue Synthesis is a 3D acoustic simulation software, designed to allow system designers and engineers to accurately predict the acoustical and mechanical performance of JBL sound systems. The software provides the ability to run three-dimensional acoustic predictions, simulate acoustic performance for complete systems, and validate mechanical configurations. The application has been designed from the ground up to take advantage of an improved acoustical and mechanical engine and offers ultra-realistic 2D and 3D graphics, featuring accurate renderings of physical rigging components.

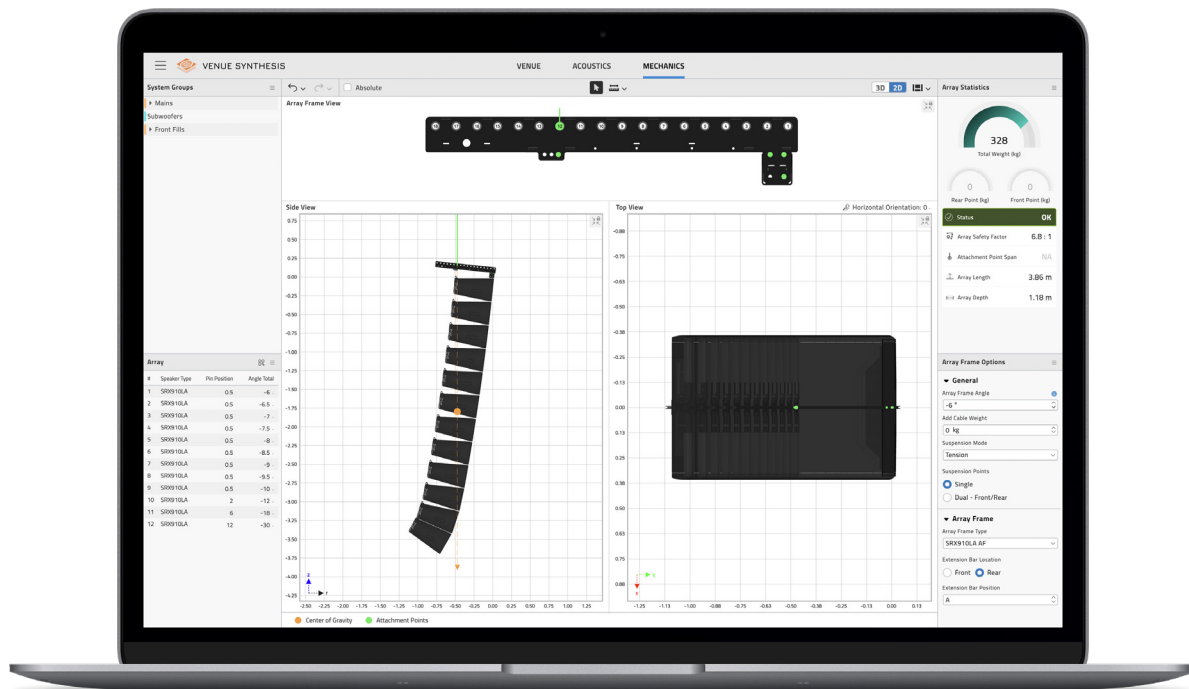

Venue Synthesis validates the mechanical properties of arrays and selected JBL accessories. Configuration limits are calculated in real time, for either suspended or ground-stacked arrays, based on array parameters such as the number of cabinets, cabinet-to-cabinet splay angles, overall array aiming, and selected accessories. In the case of suspended arrays, a safety factor is calculated to aid in designing systems that conform to local regulations. Warnings and error messages notify the user when an array or a specific accessory is outside safe working limits. For ground-stacked arrays, a tipping factor calculated from a complex set of variables suggests whether an array design is likely to be stable, potentially unstable, or unsafe. Array statistics like array size, depth, and weight are also calculated, and a PDF report facilitates system deployment. Mechanical data can be transferred to the Array Link™ app running on an iOS® or Android™ mobile phone using a QR code, with no need for Internet connectivity. All relevant rigging information and options are presented in an easy-to-understand layout.



CAUTION: All SRX900 Series systems should be designed and validated using Venue Synthesis software, this is the only way to ensure that safe mechanical conditions are met for any given configuration.

5.2 SUSPENDED ARRAYS

Venue Synthesis checks the mechanical safety of suspended arrays and takes into consideration all variables that can affect the mechanical safety and safety factors. The software validates the mechanical stresses on the enclosures, speaker rigging components, and all accessories used as part of an array. Parameters like array down angle and curvature are considered and a safety factor is generated for the given configuration. The generated safety factor value represents the minimum of any components used, and values are always rounded down.

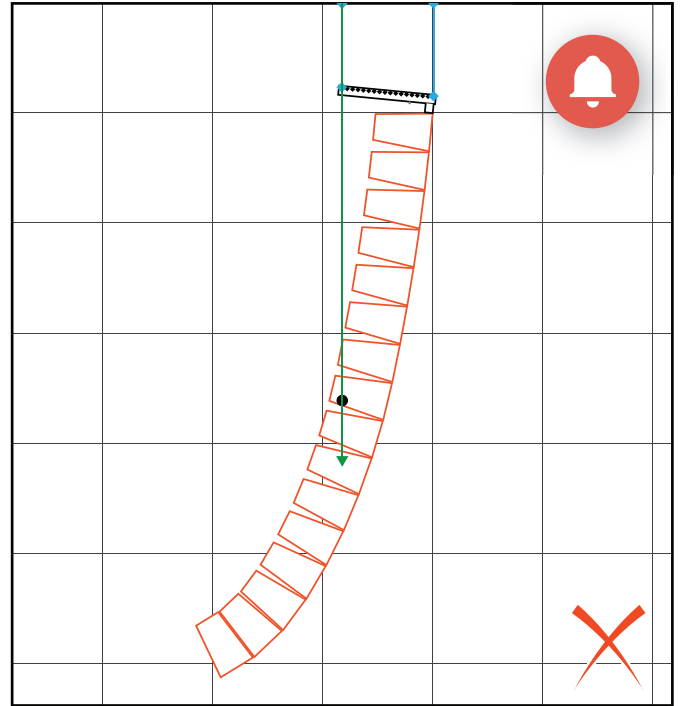
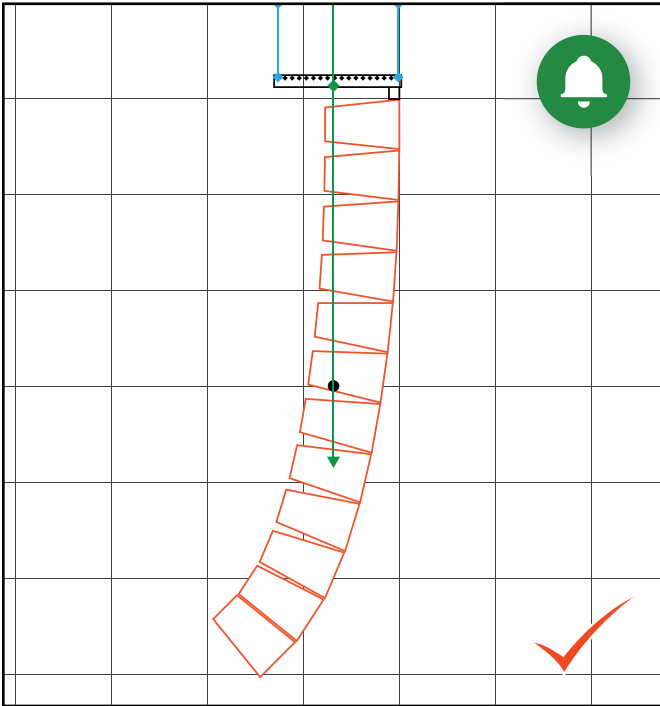

A red notification icon appears at the top of the application when the software detects a mechanical error. Select the notification icon for additional details on the issue(s). Configurations generating a mechanical error should never be used as their safety factor falls under the minimum of 4:1. The safety factor generated by the application can be used to design arrays with safety factors other than 4:1 and based on local regulations.

In addition to mechanical and safety errors, the software notifies of configurations that cannot be realized in real life. An example of such a condition is when the center of gravity of an array falls outside the footprint of the array frame. In this case, the error can be cleared by changing the down angle or using a pull-back at the bottom of the array.

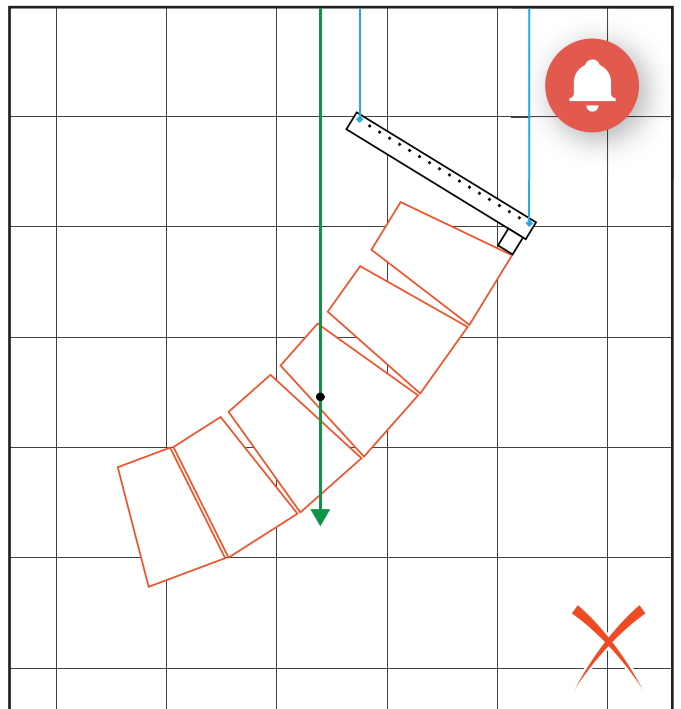

● Center of Gravity ● Suspension Points

5.3 GROUND-STACKED ARRAYS

Venue Synthesis checks for the mechanical safety for ground-stacked arrays. The software takes into consideration several variables that can affect the stability of an array, including outside factors such as someone pushing on an array. Based on this data, Venue Synthesis generates a safety assessment factor and notifies the user of potential mechanical or stability problems. Errors and warnings generated fall into one of the following categories:

No errors or messages

In this case, the array is stable under normal conditions and can be used as is. The array also complies with the mechanical limits set by JBL for the speakers and selected accessories. The notification icon will be green in color.

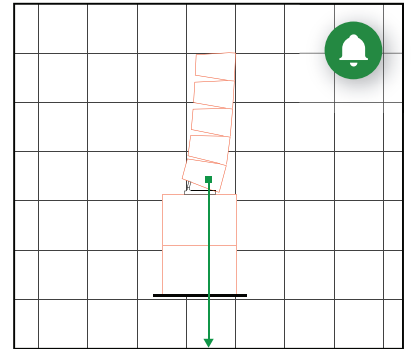

WARNING: Stability Hazard! - Stack Could Become Unstable - Secure to Ground

This message is an alert that the array is potentially unstable and a tipping hazard condition has been detected. The user is responsible for securing the array to the ground, stage, or other structure that can provide additional support and is rated for the weight of the array. This message may also be warning of external factors that can influence stability, such as someone accidentally pushing the array.

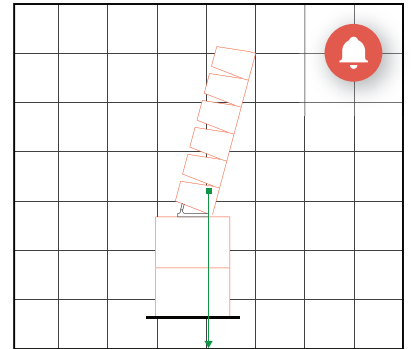

Configuration exceeds the maximum number of boxes allowed

This message is presented when the specified array design exceeds the mechanical limits set by the JBL team for the speakers or selected accessories. Array designs that trigger this message should not be used under any conditions, as they can lead to hardware damage and/or injury.

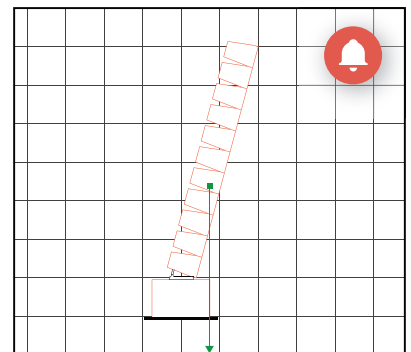

Invalid CG Location

This message is presented when the center of gravity of an array design exceeds the footprint of the selected accessory. Array designs that trigger this message should not be used under any conditions, as they can lead to hardware damage and/or injury.

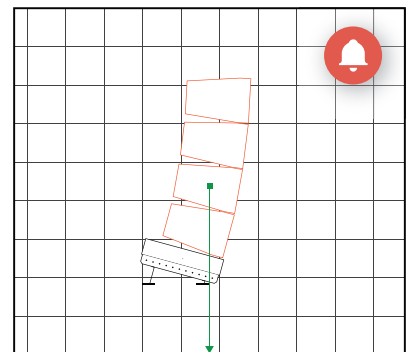

● Center of Gravity

6 - RIGGING SYSTEM OVERVIEW

SRX900 Series line array cabinets include an intuitive three-point rigging system. Angles are preselected while the system is still on the ground using the link bar, which extends vertically to the cabinet above. When an array is suspended, angles are locked using the stop pin. When it is time to de-rig the system, removing the stop pin allows the cabinets to collapse again for storage and transportation.

6.1 SRX900LA RIGGING CLOSEUP

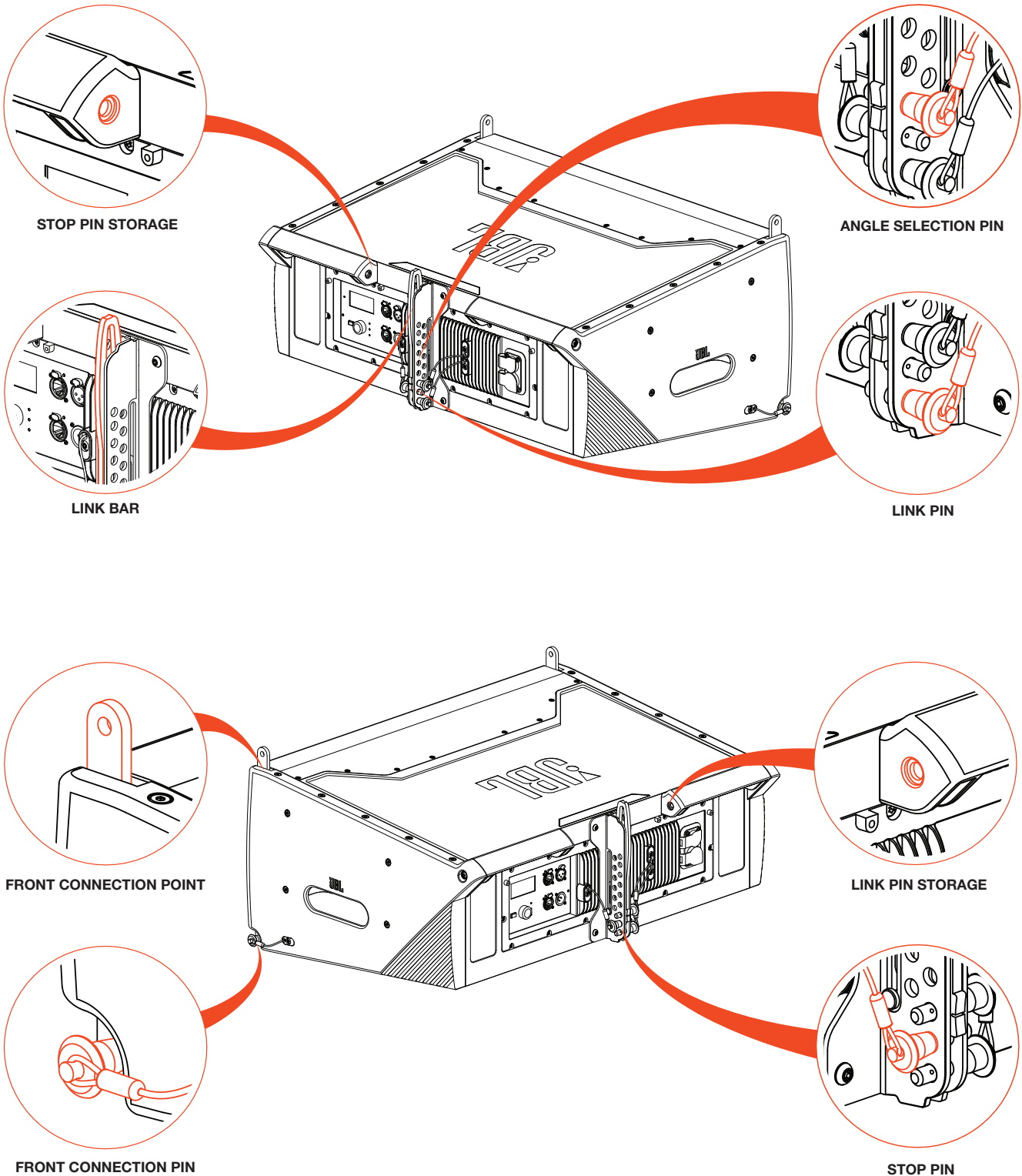

6.2 SRX900LA ANGLE SELECTION

Every SRX906LA and SRX910LA has a single angle selection plate on the center rear of the cabinet. These plates are used to select the cabinet-to-cabinet splay angle. This panel offers 13 unique positions, labeled in degrees.

SRX906LA AND SRX910LA ANGLE OPTIONS: 0.5°, 1°, 2°, 3°, 4°, 5°, 6°, 7°, 8°, 9°, 10°, 11°, 12°

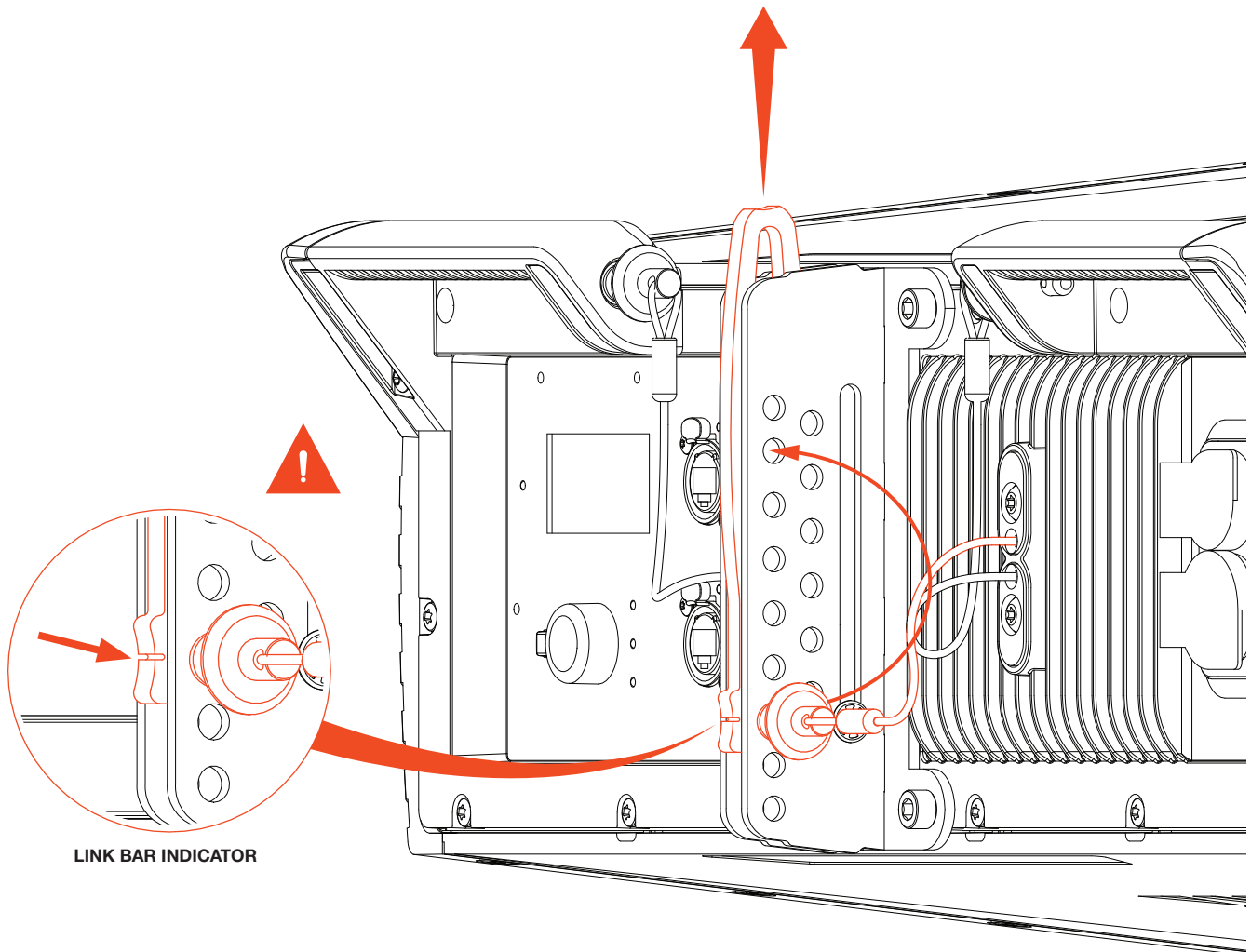

When selecting angles on a stack of SRX900 Series cabinets, always start at the top cabinet and work down to the lowest. Angles are selected while SRX900 Series cabinets are on the carts and resting on the ground. Since the rigging mechanism is not under load when the system is on the ground, the link bar can be moved freely to the desired position.

To select an angle, remove the angle pin from the 12° STORAGE position and extend the link bar upwards. Align the link bar indicator with the desired angle indicator on the angle selection plate and re-insert the pin into the corresponding angle hole. Lifting the array from the ground shifts weight to the quick release pins, making angle selections no longer safe or possible.



CAUTION: Every quick release pin in an SRX900 Series system must be set in a hole before the array is flown. Do not suspend an SRX900 Series system if any pins hang free.

6.3 SRX900SF RIGGING CLOSEUP

Flown SRX900 subwoofers include a captive three-point rigging system designed to suspend standalone subwoofer arrays or mixed arrays using SRX900LA full-range cabinets suspended underneath. The spring loaded front connection points and the magnetic rear connection point are easily deployed for suspension but are securely stowed under tension when not in use to prevent audible artifacts from vibration.

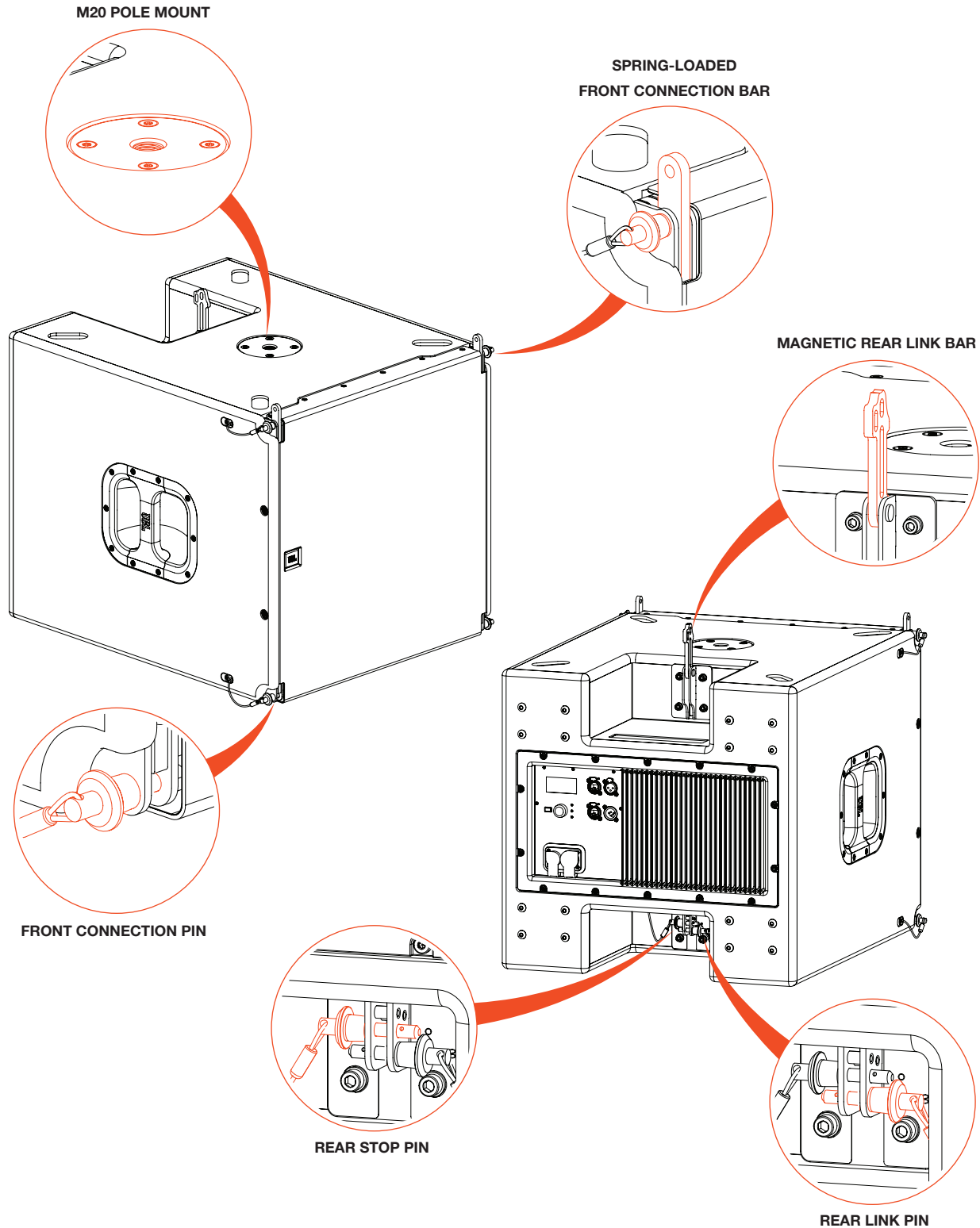

6.4 DEPLOYING THE SRX900SF FRONT CONNECTION BARS

The two front SRX900SF Connection Bars are stowed when not in use and need to be deployed prior to suspending. The bar automatically extends upwards once the pin is removed.

STEPS:

- 1 Temporarily remove the quick release pin for each position, the front connection bar will automatically extend upwards.
- 2 Reinsert the quick release pin to lock the connection bar into the deployed position.

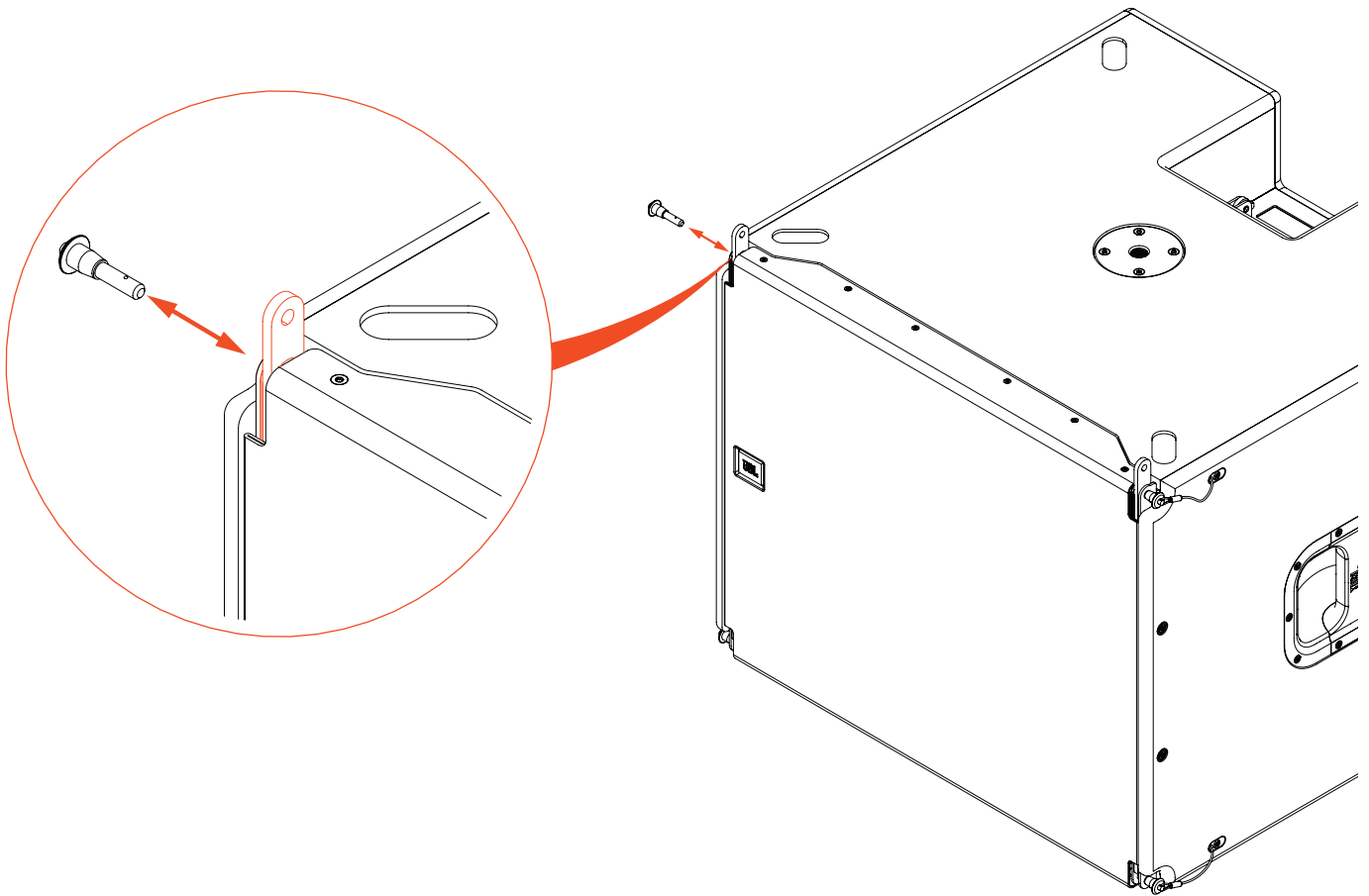

CAUTION: No quick release pins should be left unused when deploying SRX900SF cabinets in suspended configurations.

7 - TRANSPORTATION

Each component in the SRX900 Series has a convenient and efficient transportation system. The SRX906LA and SRX910LA are both transported in stacks of four cabinets with their angles fully collapsed. The SRX906LA cabinets ride inside of a road case and the SRX-910LA cabinets travel on a vertical transport cart. SRX900 Series subwoofers have mounting points for casters, allowing users to install the ACK1 caster kit for single subwoofer transportation. Alternatively, Vertical Transporters can be used to transport SRX900 subwoofers in stacks up to three units high.

Soft covers are available for the SRX910LA, and for all subwoofers models in either transportation configuration to protect the cabinets .

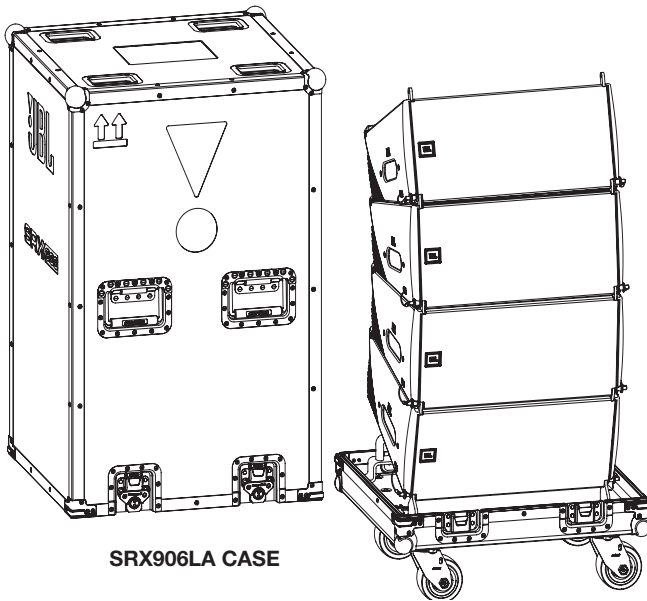

SRX906LA CASE

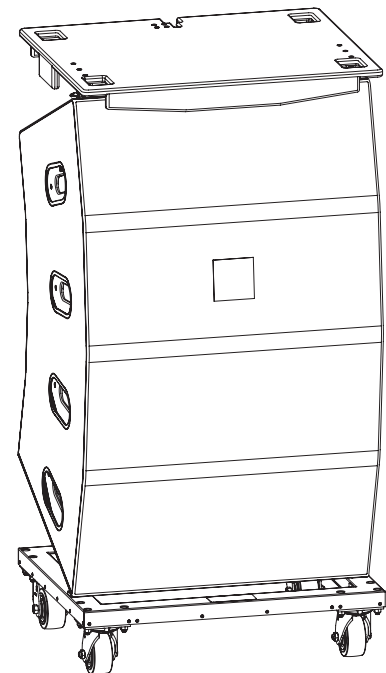
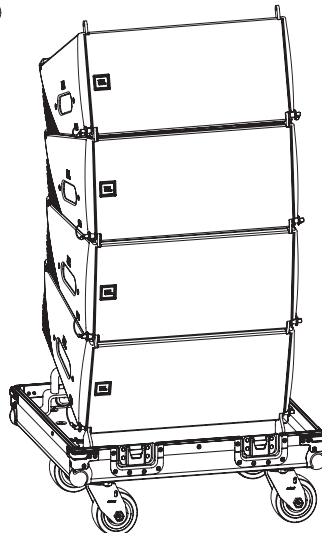

SRX910LA VT + VT CVR

SRX915S CVR

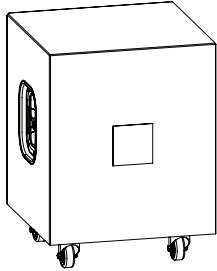

SRX918S CVR

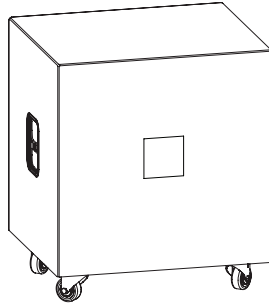

SRX918SF CVR

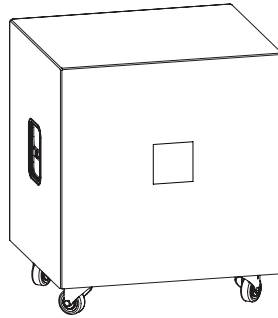

SRX928S CVR

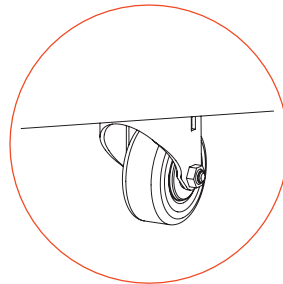
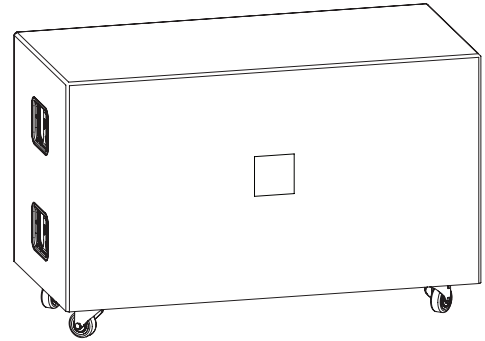

ACK1 CASTER KIT

SRX928S VT CVR

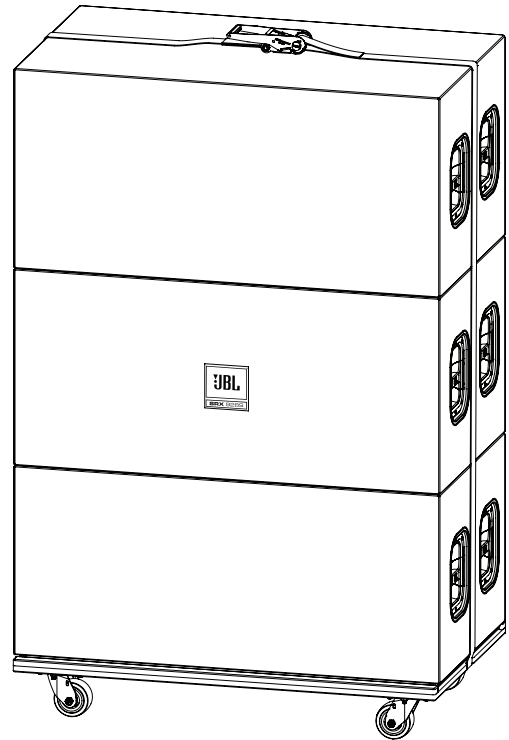

SRX915S VT

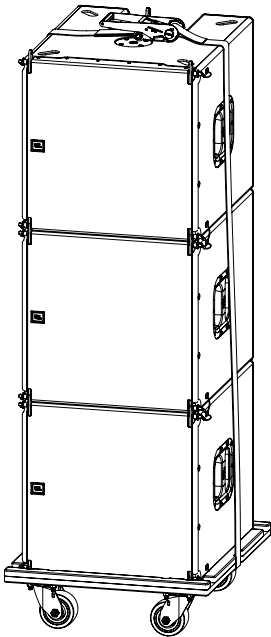

SRX918S VT

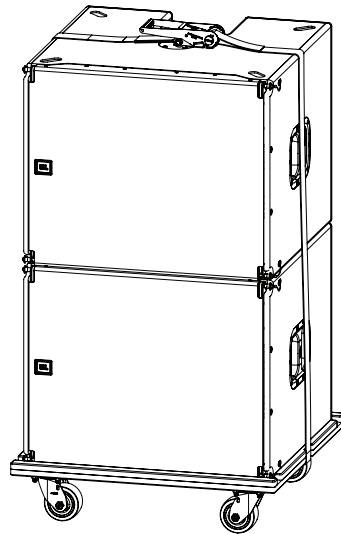

SRX928S VT



TIP: SRX900 Subwoofer VT's and VT CVR's can be used to transport stacks of two or three subwoofers.

7.1 INSTALLING CABINETS ON THE SRX900LA CASE OR VT

Both of the SRX900LA cabinets attach to their respective transport carts the same way, the following set of instructions is valid for both the SRX906LA with the SRX906LA Case as well as the SRX910LA with the SRX910LA VT.

STEPS:

- 1 Prepare the first SRX900LA by setting the link bar to the 12° position and installing the link pin into the LINK position.
- 2 Install the two front pins to secure the first cabinet to the front brackets of the Case or VT.
- 3 Lift the rear of the cabinet (use the handle) and align the rear mounting bar.
- 4 Lower the cabinet and set the hook.
- 5 Insert the STOP pin.

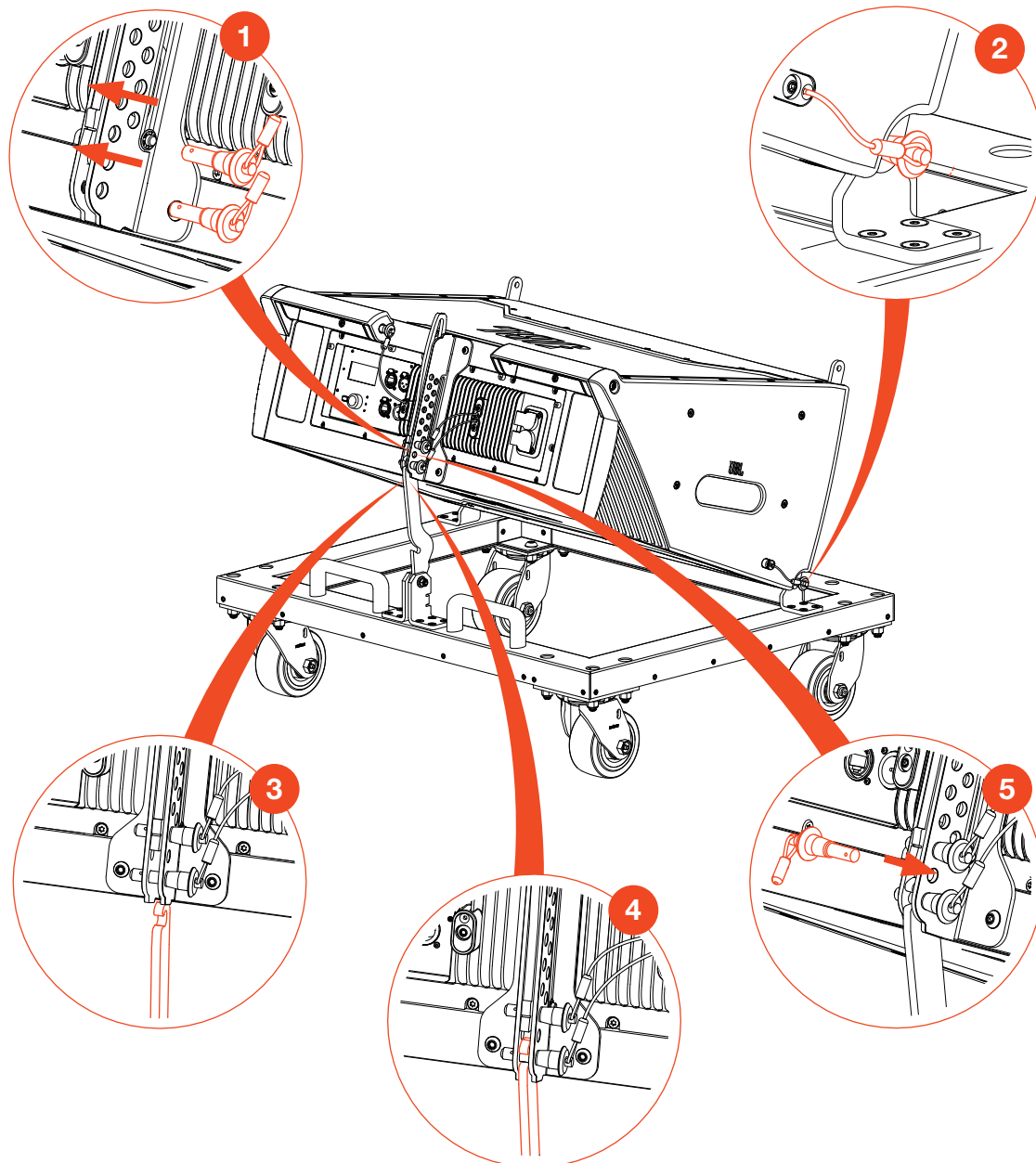

STEPS (Continued):

- 6 Prepare the next enclosure by setting the link bar to the 12° position, storing the stop pin in the handle, removing the link pin and the two front pins.
- 7 Lower the next SRX900LA cabinet onto the first enclosure and secure the two cabinets together at the front using the pins.
- 8 Insert the link pin into the LINK PIN hole of the angle selection mechanism, pinning through the link bar of the cabinet below.
- 9 Repeat this process until all four cabinets are secured.

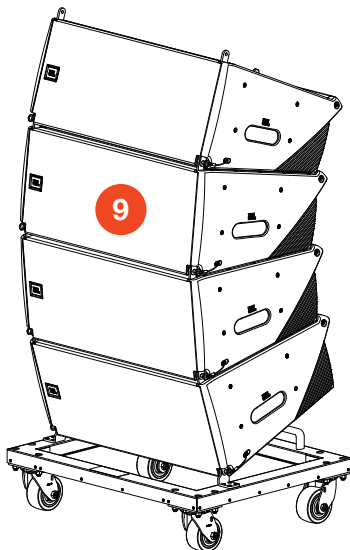
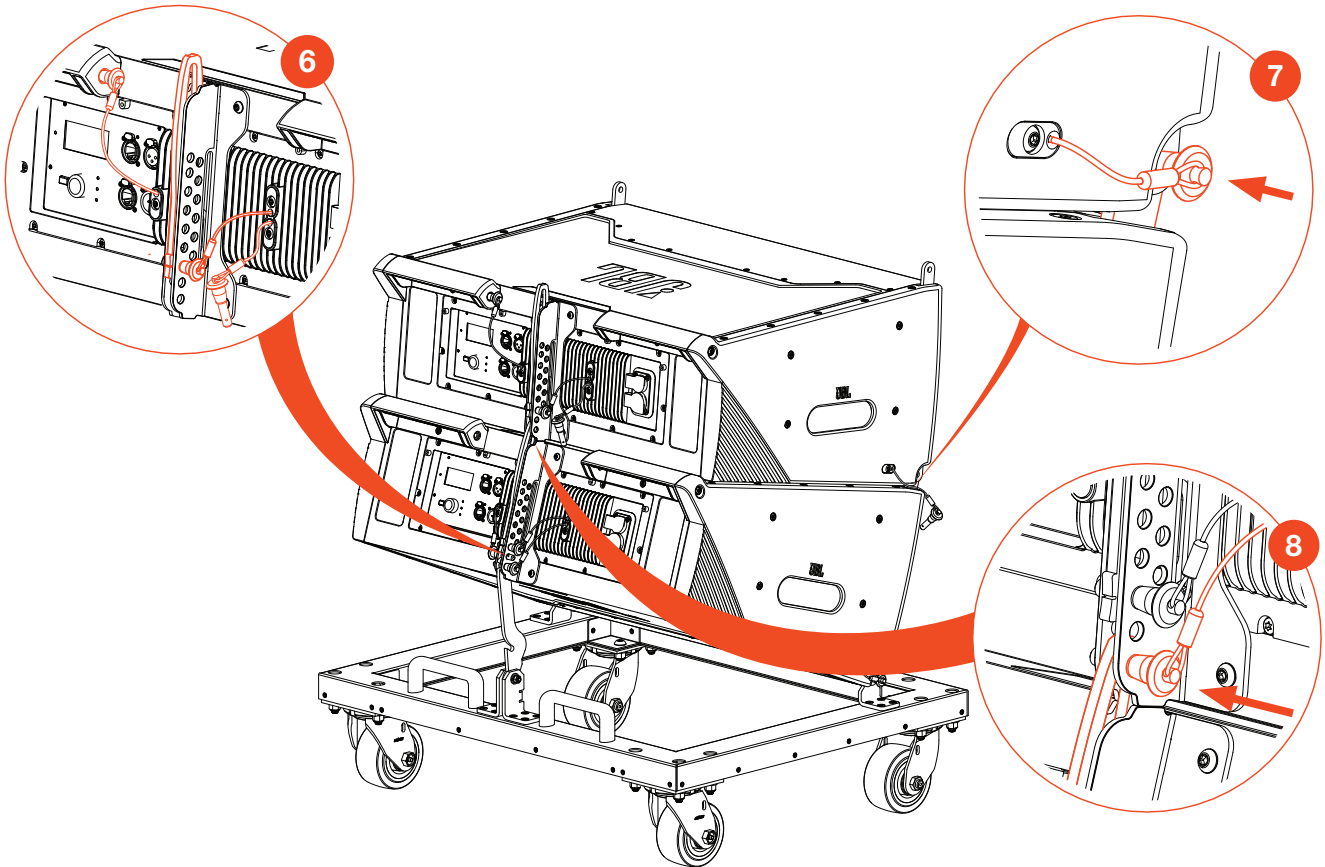

7.2 INSTALLING THE SRX910LA VT-TOP

The VT-TOP connects to the top cabinet of an SRX910LA stack to form a robust and defined footprint that stabilizes the carts during transportation. The flat top allows other gear to be stacked on top of SRX910LA arrays traveling on SRX910LA VT carts for a more efficient truck pack.

STEPS:

- 1 Set the top cabinet's link bar to the 12° (Storage) position and lower the VT-TOP onto the cabinet.
- 2 Install the two pins at the front.
- 3 Unpin the VT-TOP rear mounting arm and use the pin to attach the arm to the top cabinet's link bar.

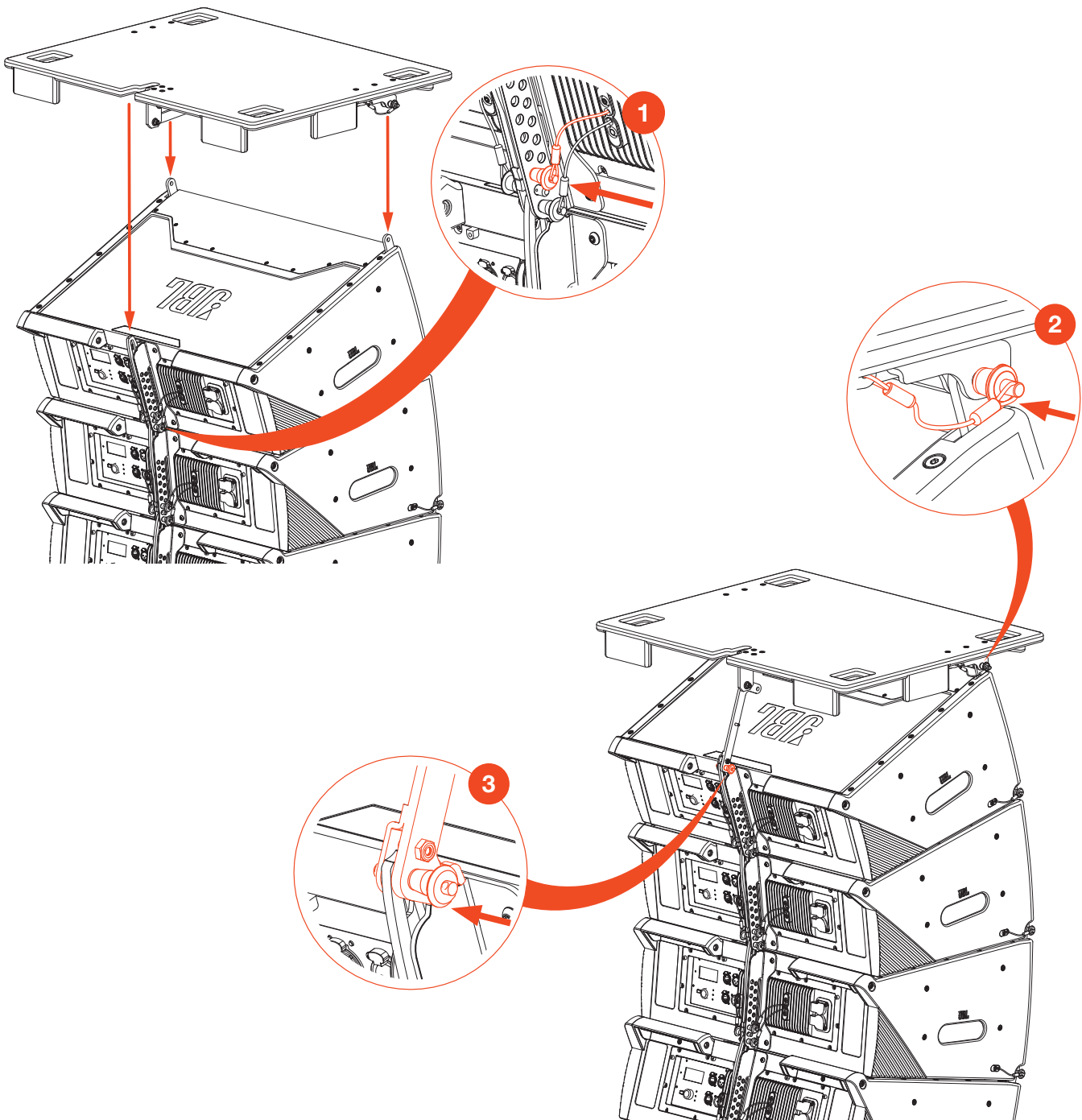

7.3 STORING THE SRX910LA VT

Once an SRX910LA stack has been deployed, the VT-TOP can attach to the SRX910LA VT for storage. Several carts can be stacked together for storage.

STEPS:

- 1 Pin the rear attachment point of the VT-TOP into the storage position.
- 2 Slide the VT-TOP into the storage slot of the VT BOTTOM rear attachment bar.
- 3 Pin the front attachment brackets.

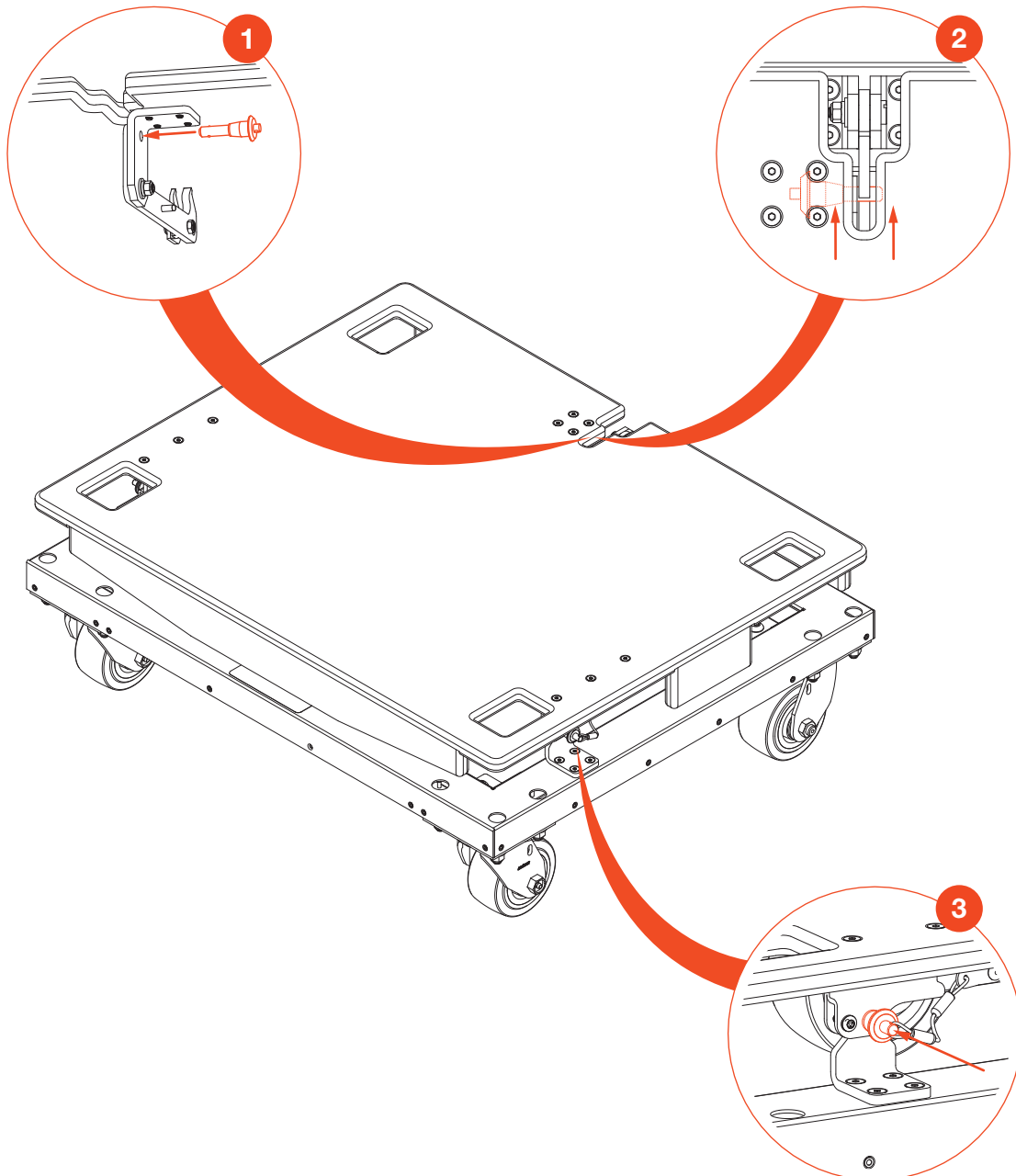

TIP: There is a cutout on the VT-TOP to look down through while sliding the pin of the VT-TOP into the storage slot.

7.4 STACKING THE SRX910LA VT

When the SRX910LA VT and VT-TOP are attached, several assemblies can be stacked together for storage.

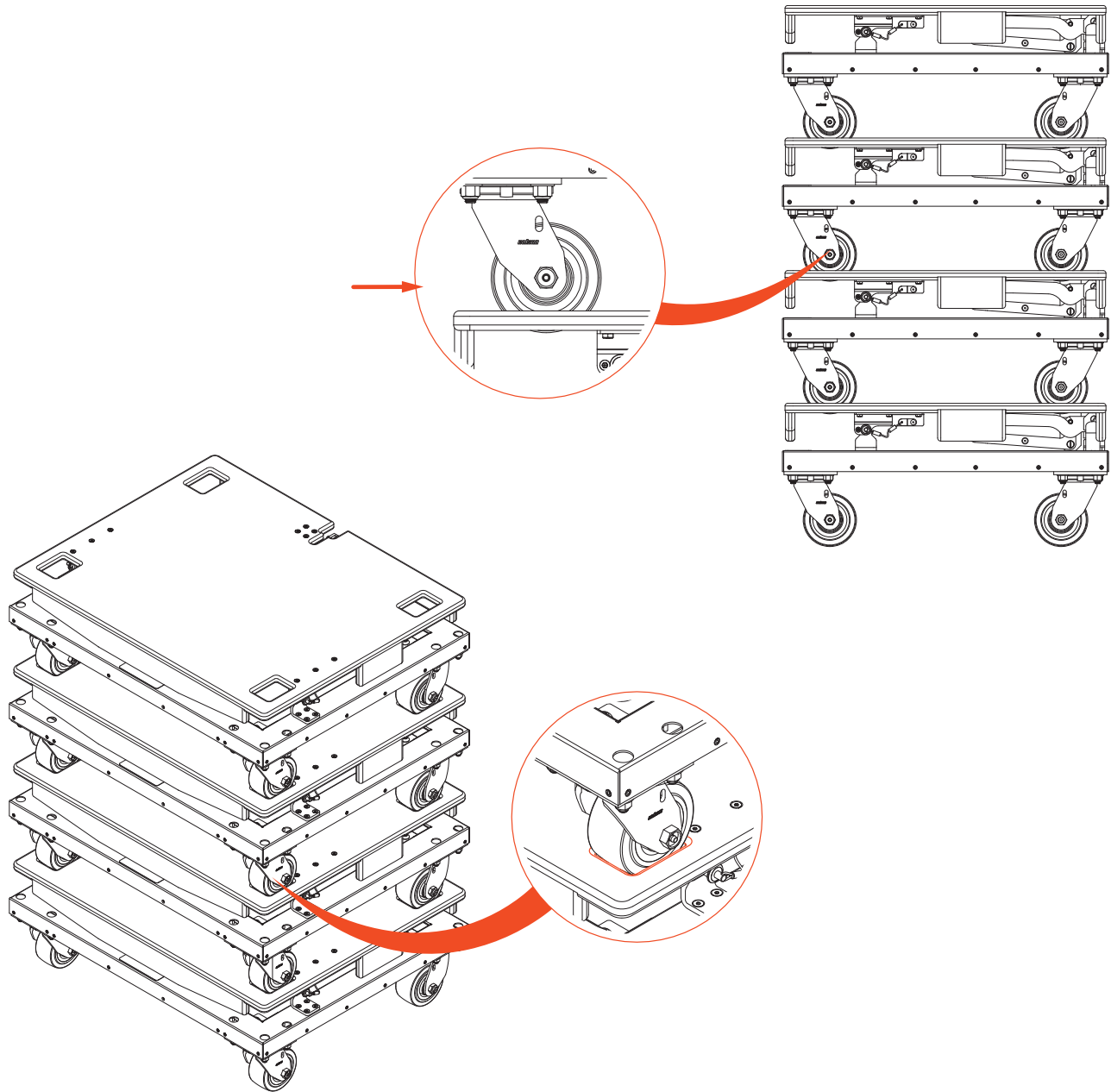

7.5 INSTALLING THE ACK1

The universal ACK1 caster kit can be installed on any of the four SRX900 subwoofer models. Each kit includes the casters and hardware needed for a single subwoofer.

STEPS:

- 1 Remove the four bolts that were pre-installed into the threaded M10 nuts.
- 2 Using the included hardware, place one split lock washer and then one washer onto each of the four bolts.
- 3 Line up the caster and re-install the four bolts and washers through the caster holes.
- 4 Repeat for the remaining three corners.

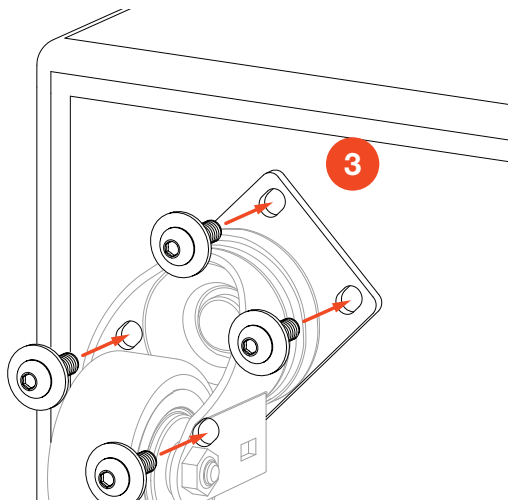
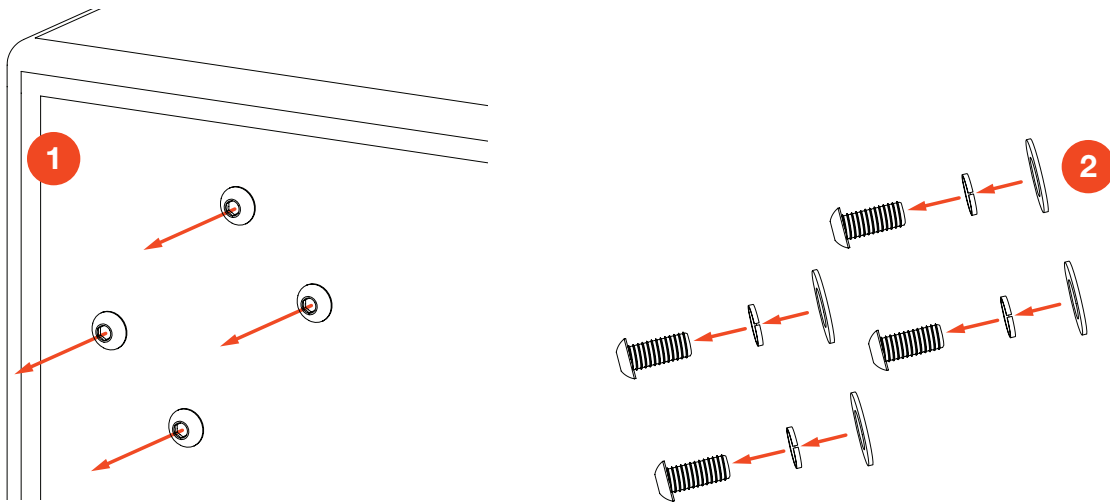

TOOLS REQUIRED: A 3/16 in. Allen Key is required to install the ACK1 caster kit. Apply a torque value of 3.9 Nm (35 in-lbs) and non-permanent thread lock.

7.6 INSTALLING SRX900 SUBWOOFERS ON A VT

Each of the three subwoofer sizes has a corresponding vertical transporter (VT) cart to transport stacks of one to three units. Regardless of the VT size required, the instructions to stack and secure subwoofers to the cart are the same.

STEPS:

- 1 Place the first subwoofer onto the cart so that the feet sit securely into the matching grooves on the VT with the grill facing the direction of the arrow.
- 2 Stack 1-2 more matching subwoofers on top of the first cabinet.
- 3 Secure the stack of subwoofers to the cart with the included ratchet strap.

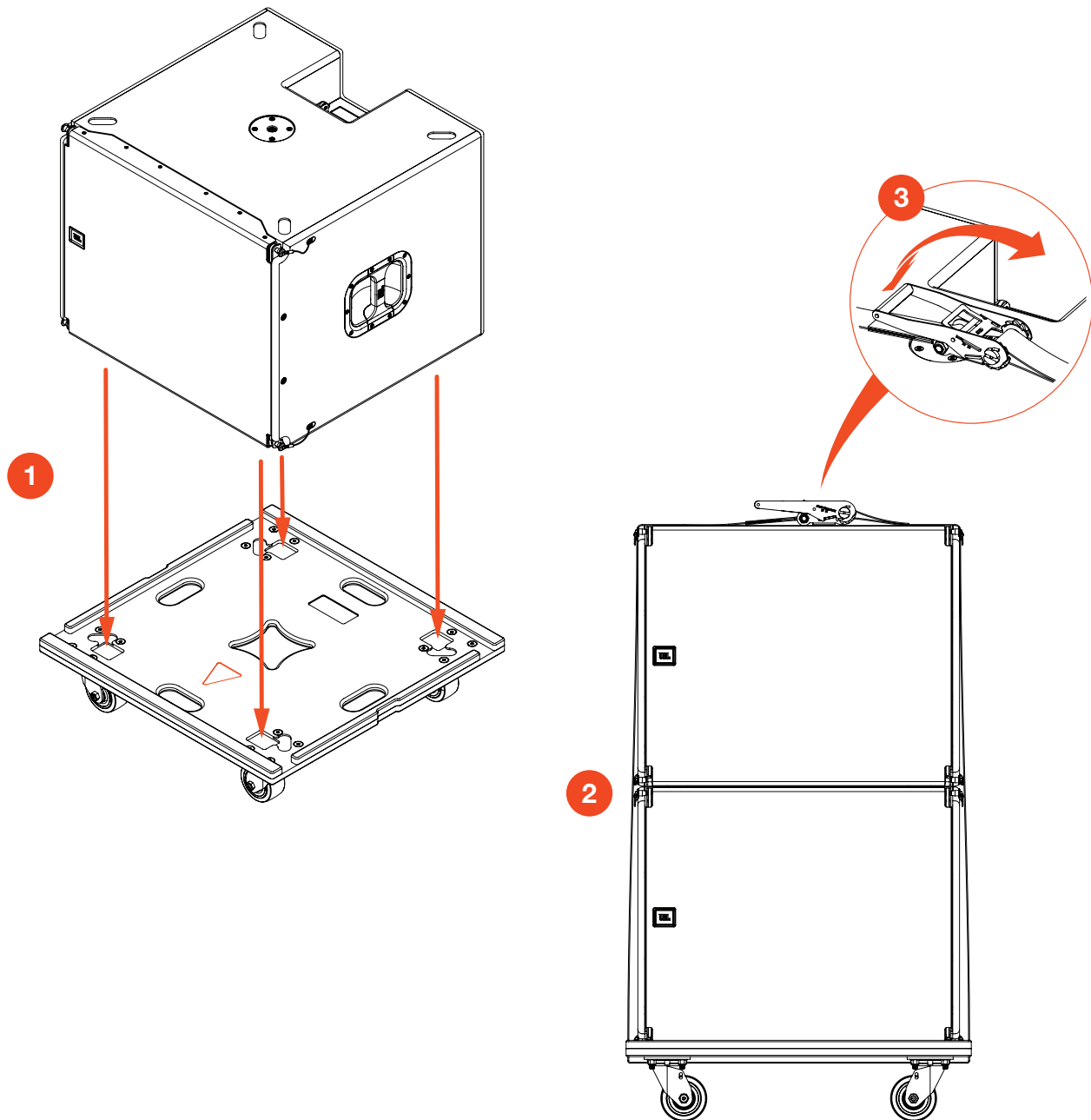

TIP: When stacking SRX915SF and SRX918SF subwoofers on a VT, the cabinets can be connected together using the boxes rigging hardware. See **Section 10.2 Attaching the Next Subwoofer** for details on this process.

8 - ARRAY FRAMES

The SRX906LA and SRX910LA AF Array Frames are used for suspending SRX900 Series arrays. Although different in size, the two frames are functionally identical. The array frames were designed to work with single-point and front-back suspension methods. For single-point applications, the array frame can be used in conjunction with the VTX RC500 rotating clamp, allowing smaller arrays to be suspended from standard size trusses or pipes. The two-piece design is comprised of one extension bar and one spreader bar. The extension bar can extend to the front or rear of the frame to accommodate both uptilt and downtilt aiming options. Three connection points are available for attaching the extension bar to the spreader bar, allowing for precise control of shackle positioning for single-point applications. Support for third-party inclinometers is available using the included laser attachment bracket.

8.1 ARRAY FRAME OVERVIEW

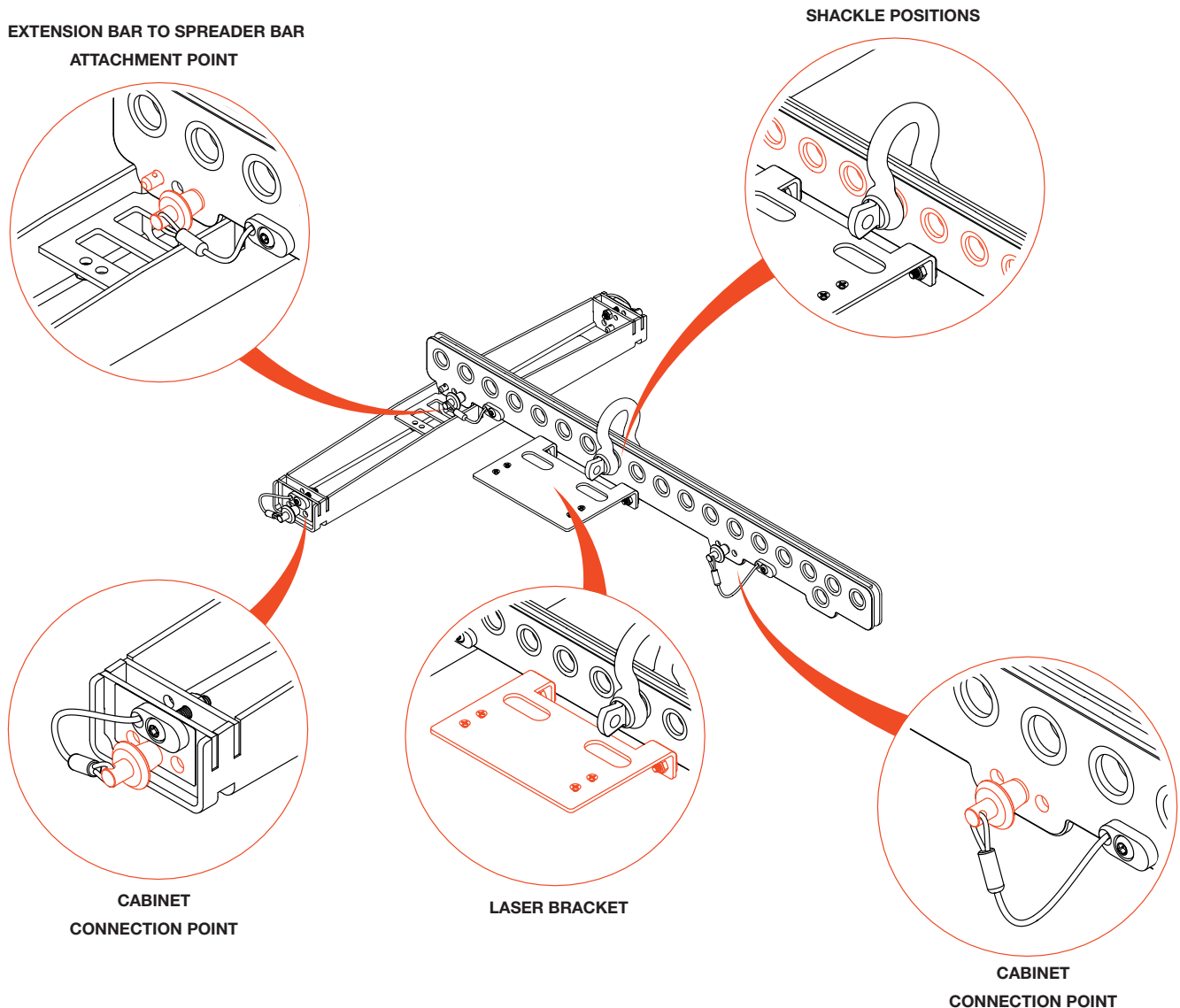

TIP: The SRX906LA AF and SRX910LA AF Array Frames are only compatible with 1/2-inch shackles. One 1/2-inch shackle is included with every SRX906LA AF and SRX910LA AF.

8.2 ATTACHING THE EXTENSION BAR TO THE SPREADER BAR

The extension bar includes two pins for attaching to the spreader bar. An additional pin attached to the spreader bar is used in conjunction with one of the pins attached to the extension bar to create the completed array frame assembly.

STEPS:

- 1 Lower the extension bar onto the spreader bar attachment tab.
- 2 Use the two included pins to secure the extension bar to the spreader bar. One pin runs from the extension bar and the other from the spreader bar.

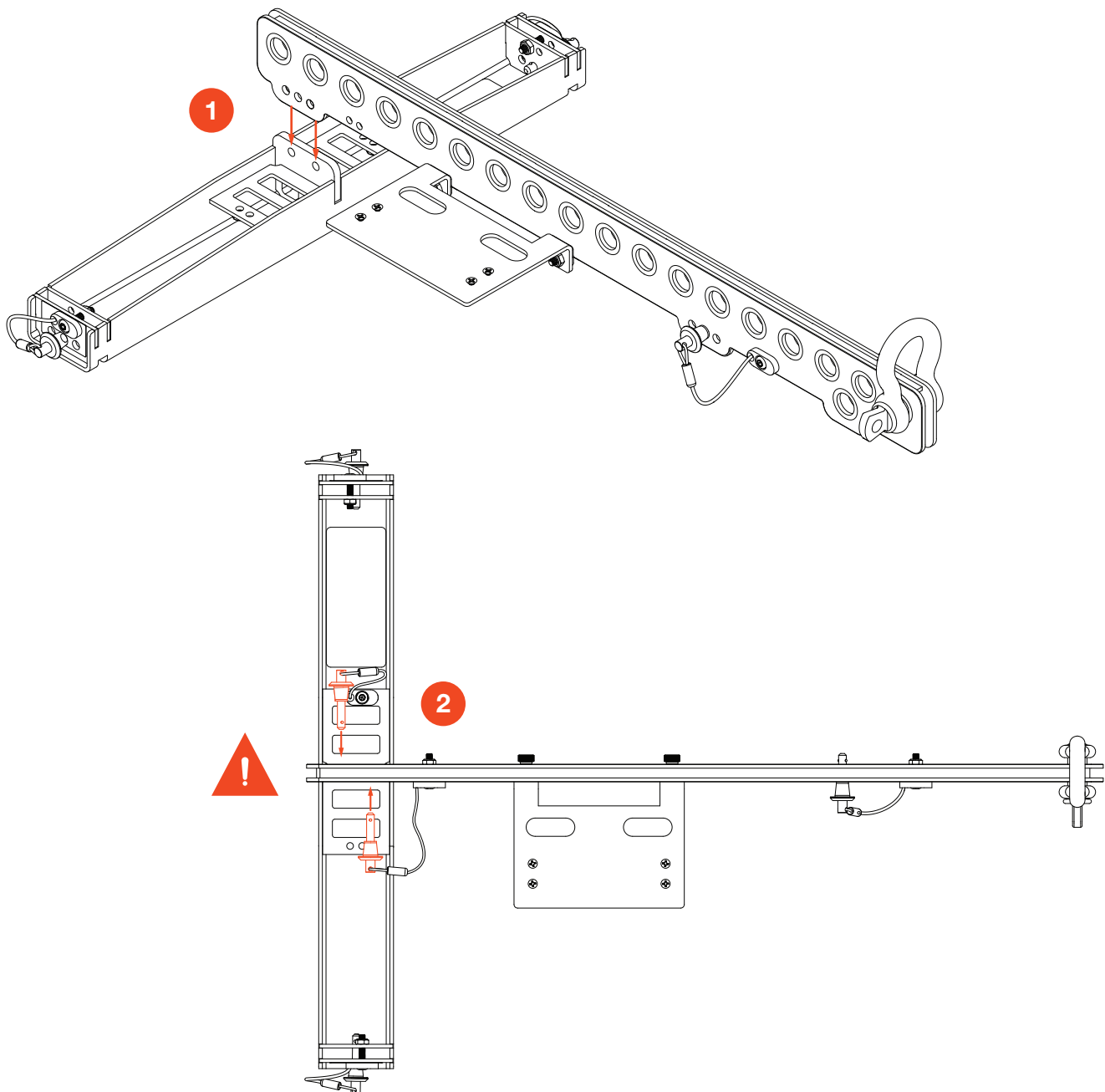

CAUTION: Always use both included quick release pins to attach the extension bar to the array frame. Inspect both connection points before suspending an array.

8.3 ARRAY FRAME ATTACHMENT OPTIONS

The extension bars include three attachment positions for connection to an array, allowing for greater aiming resolution when an array is suspended from a single point. In single-point applications, array aiming is determined by the shackle position on the extension bar. The extension bars includes a good number of shackle positions, however the spacing is typically too coarse for precise sub-degree aiming, and a shackle position is needed between two holes. The three attachment positions (A, B and C) allow for two additional shackle positions between holes, increasing the total shackle positions.

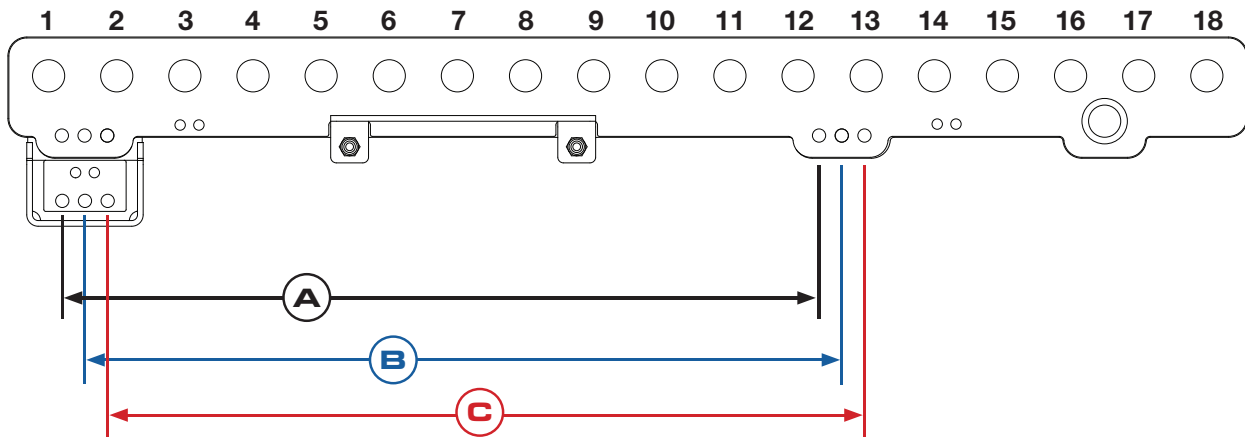

The example below shows how the real and “virtual” positions are spaced across the extension bar.

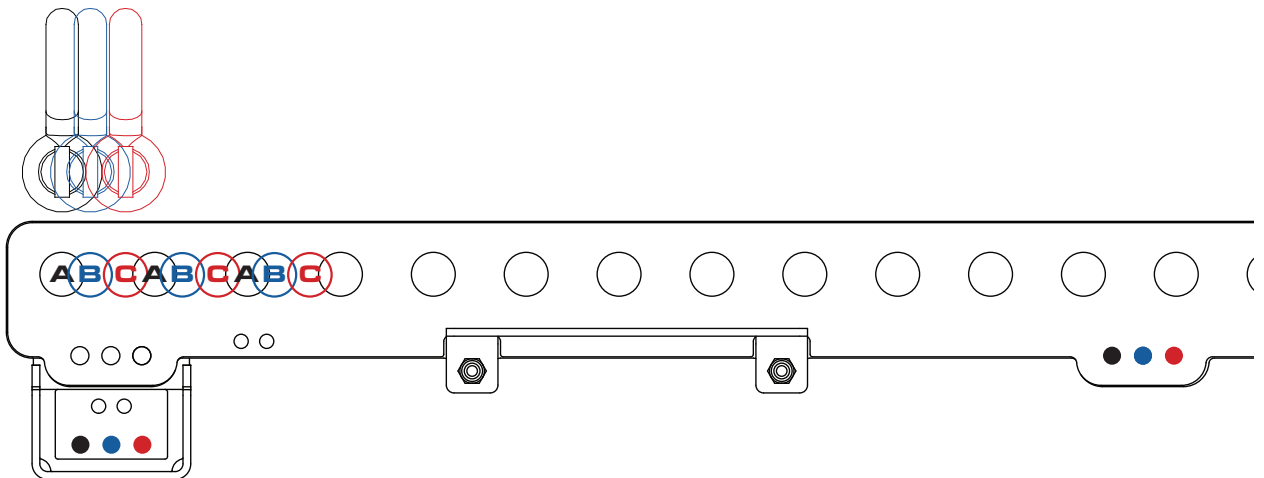

TIP: Refer to the Venue Synthesis software to determine the best shackle position and attachment combination to achieve the required array angle.

8.4 EXTENSION BAR POSITIONING

When the extension bar is attached to the array frame in its normal orientation, it extends towards the rear of the array, permitting the maximum possible downtilt for the array. The extension bar also can be attached in a reversed position, which provides the maximum possible uptilt. This orientation is typically used when the array is trimmed lower than the highest seat of the venue and required to point upwards. The cabinet connected to the array frame is always set to the 0.5° (AF) position regardless of the extension bar orientation.

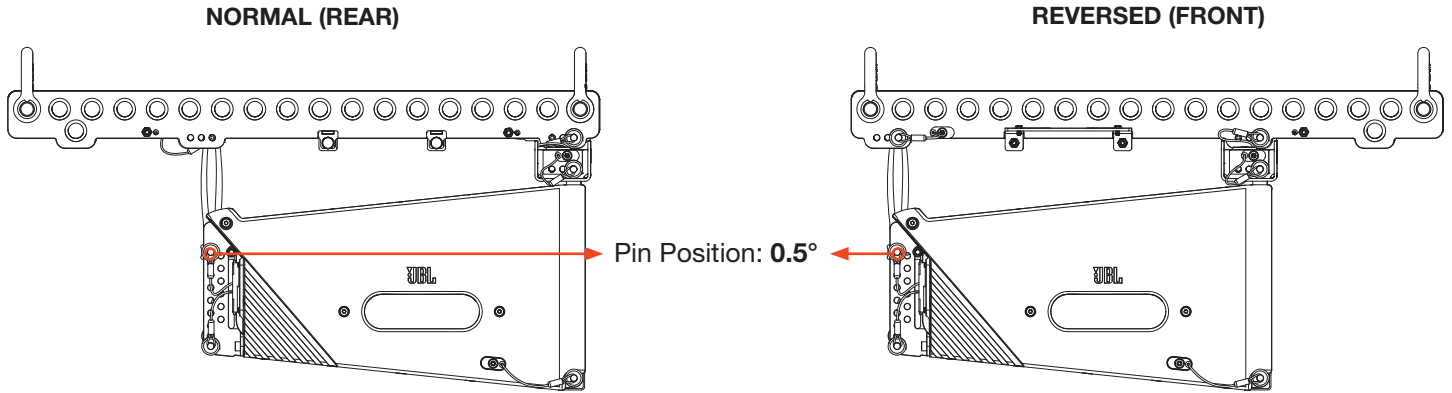

NORMAL EXAMPLE

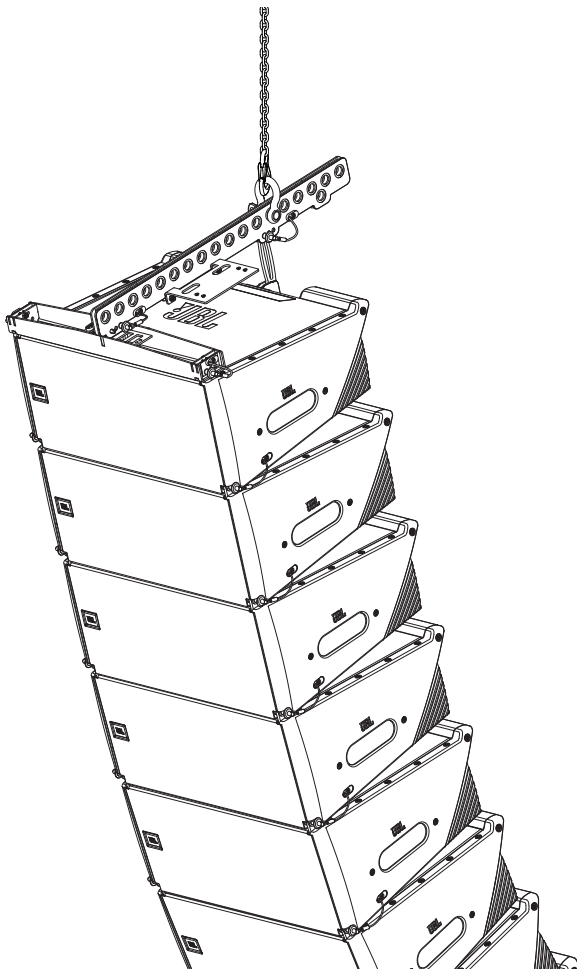

REVERSED EXAMPLE

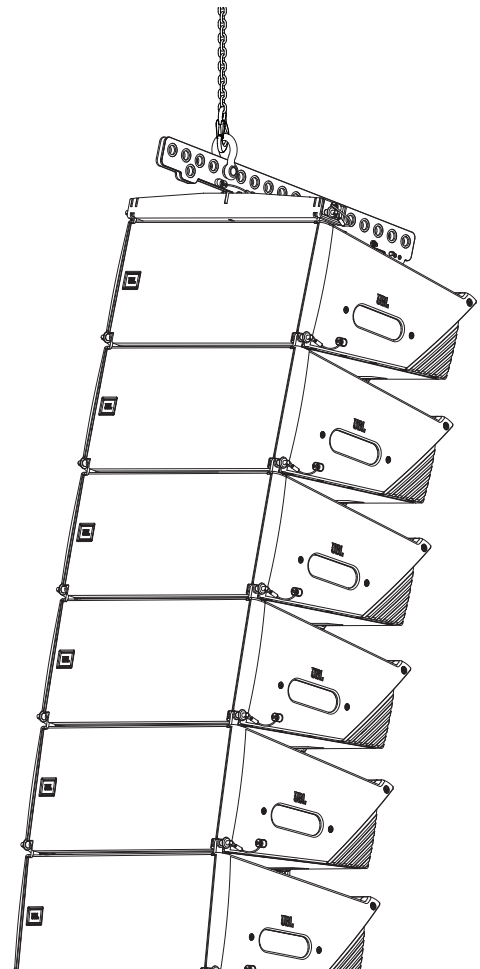

8.5 INSTALLING THE LASER BRACKET

The array frames includes a mounting bracket that enables installing a third-party laser inclinometer on the array frame. The included laser bracket was designed to work with various industry standard systems.

STEPS:

- 1 Secure the laser to the bracket using the four included screws.
- 2 Install the laser bracket to the extension bar with the included thumb screws. The extension bar's orientation determines whether the bracket should face the forward or reversed side of the extension bar.

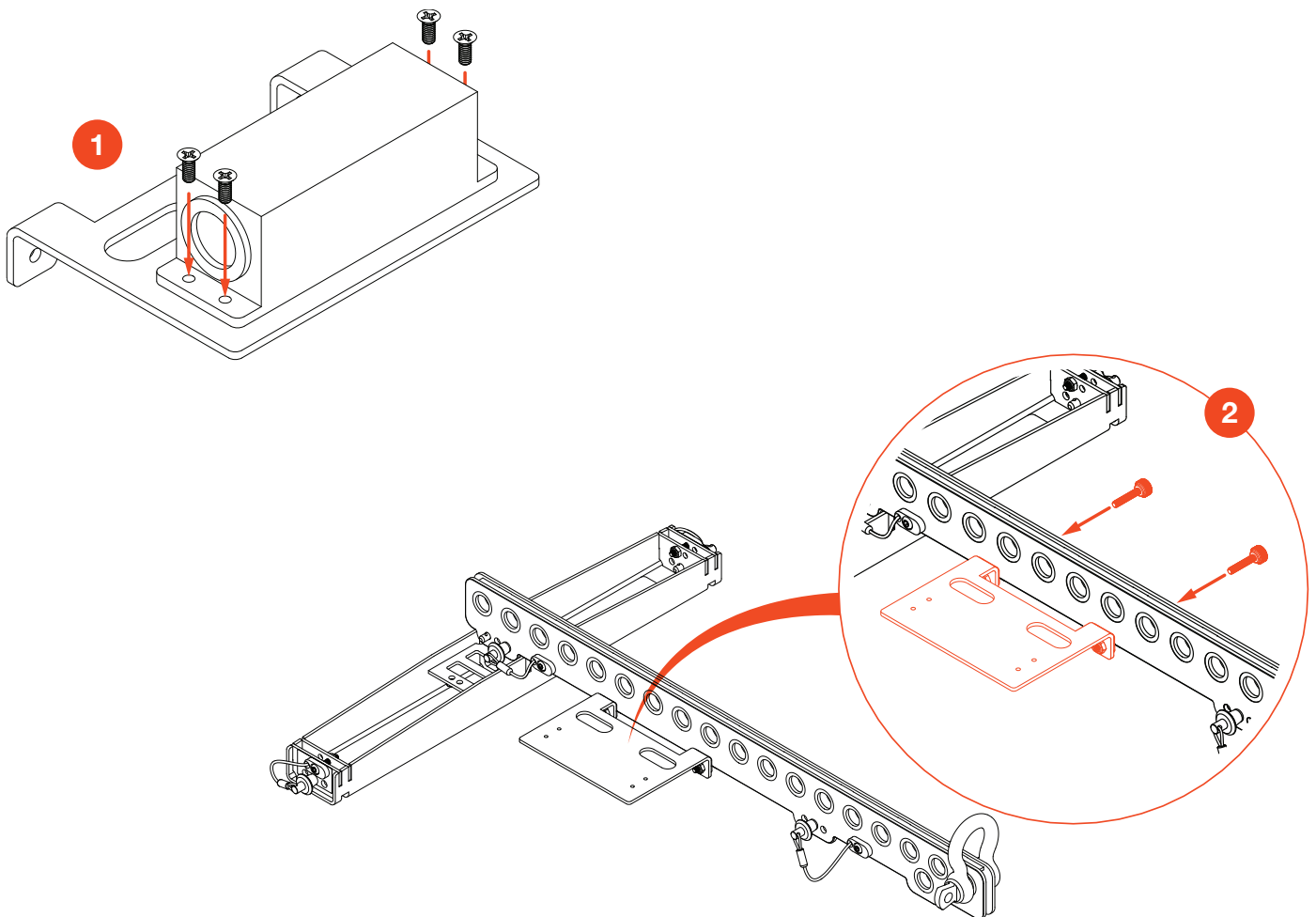

TOOLS REQUIRED:

- A Phillips #2 screwdriver is needed to attach the laser to the bracket. All necessary hardware is included.



TIPS:

- Additional laser brackets can be purchased separately (Part Number #5128892).
- Two positions are available on the laser bracket for a safety tether.
- Make sure to orient the laser bracket appropriately before installation.

9 - DEPLOYING ARRAYS

Carefully follow the steps in this chapter to correctly and safely suspend an array of SRX900LA Cabinets. Although an SRX910LA array is pictured in the chapter, the process is the same for both SRX906LA and SRX910LA systems.

9.1 SET THE ANGLES FOR THE FIRST SET OF CABINETS

STEPS:

- 1 Starting from the top cabinet, remove the angle selection pin from its 12° STORAGE hole.
- 2 Slide the link bar up so that the angle indicator line is aligned with the intended splay angle. Insert the pin into the corresponding hole to secure the link bar. If this is the first cabinet in an array, the link bar should be set to the 0.5° position for attachment to the array frame.
- 3 Repeat Step 2 and 3 for all cabinets in the transport stack working from the top cabinet to the bottom cabinet.

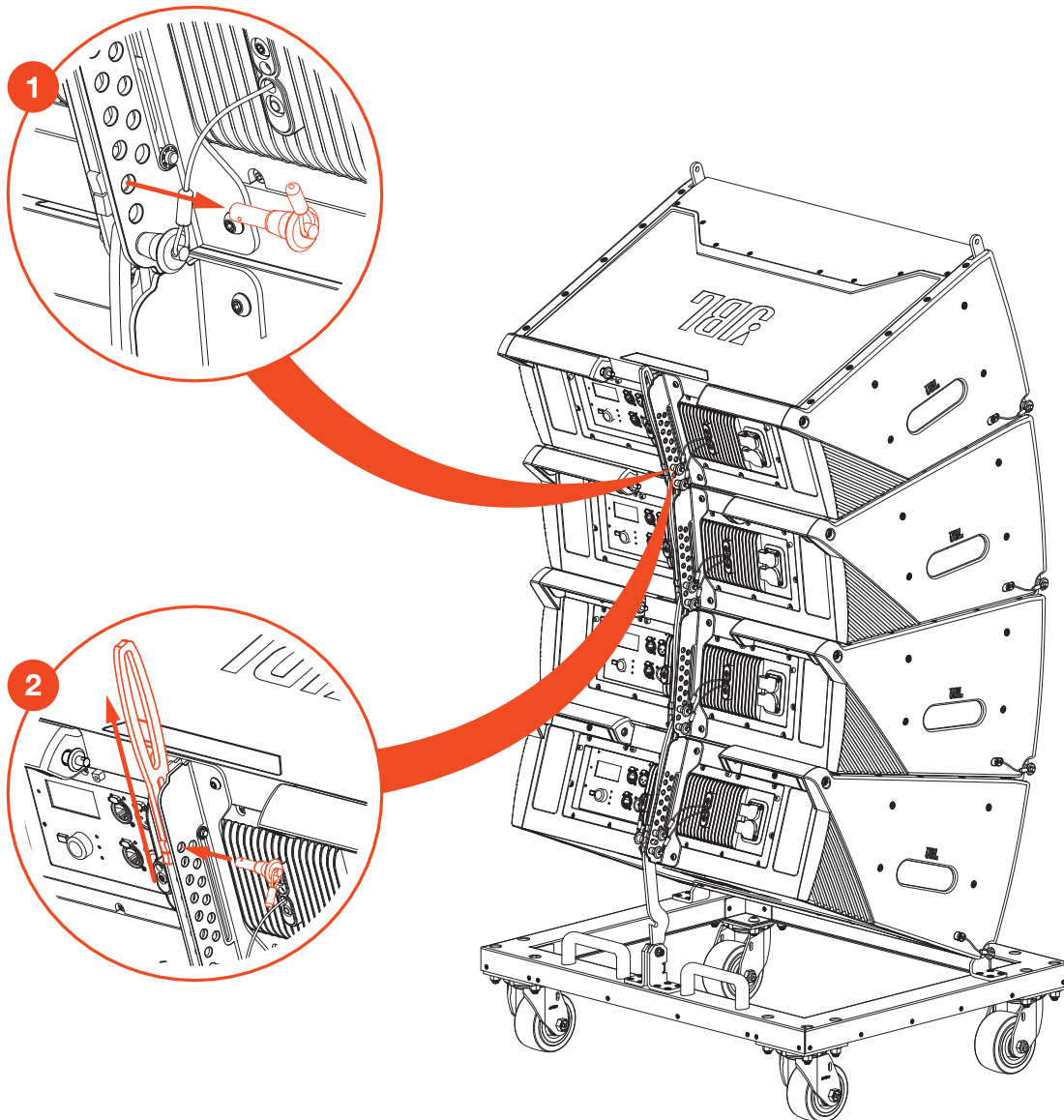

9.2 ATTACHING THE ARRAY FRAME

After setting the angles of the first stack of cabinets in an array, follow the steps below for attaching the array frame. For easiest attachment, separate the spreader bar from the extension bar.

STEPS:

- 1 Verify that the top cabinet is set to 0.5 degrees. Place the spreader bar on the top cabinet between the front two attachment points and insert the pins. Consult Venue Synthesis software to determine whether the A, B, or C position is used. Ensure that both sides are pinned in the same position.
- 2 Pin the extension bar to the spreader bar using the two pins provided. Consult Venue Synthesis for proper orientation. Ensure that both pins are used to secure the two pieces together.
- 3 Pin the link bar of the top cabinet to the extension bar. Make sure to use the same A, B, or C position used in Step 2.
- 4 Attach the 1/2-inch shackle to the correct hole on the extension bar and connect the hoist.

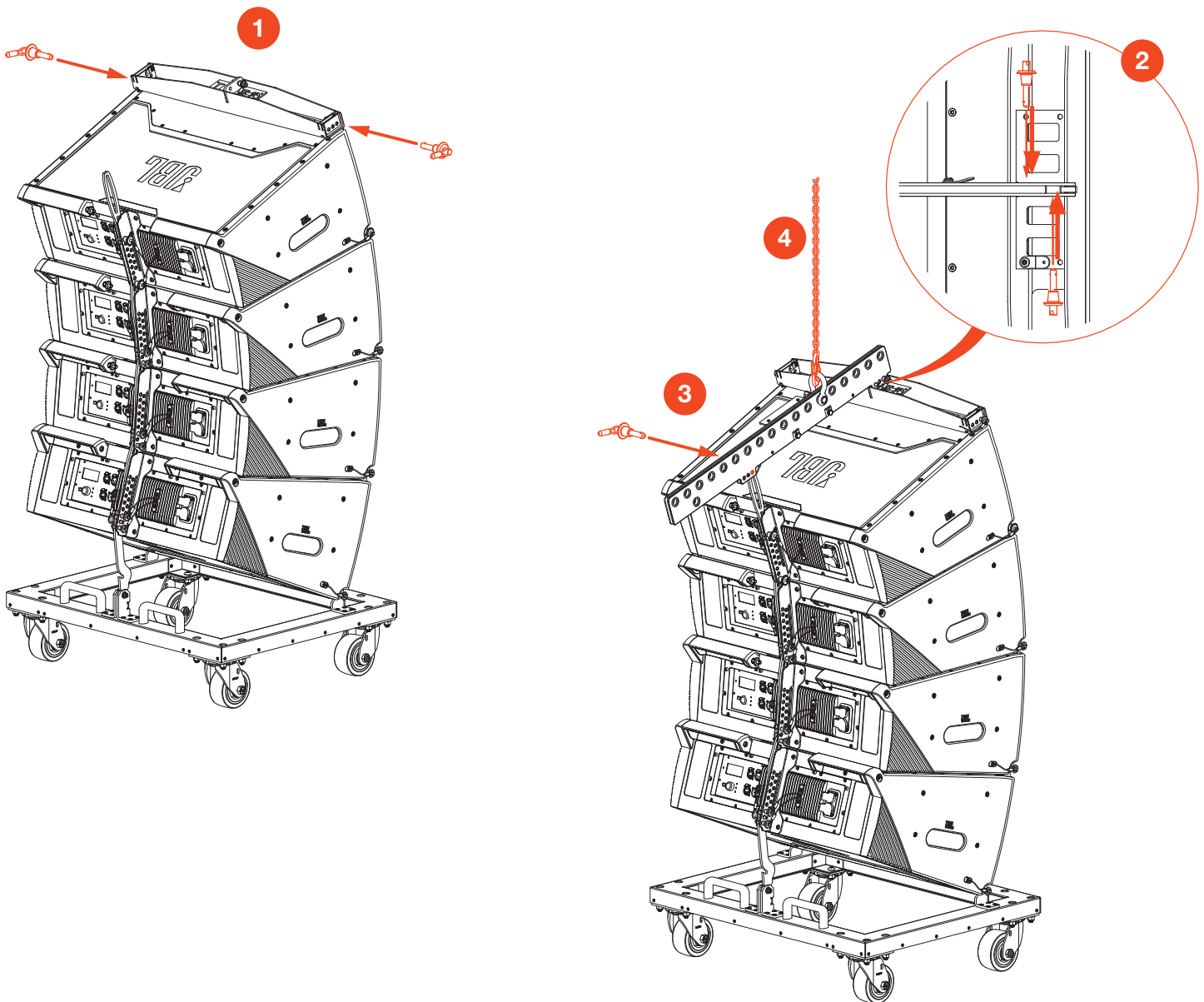

9.3 SUSPEND THE FIRST STACK

STEPS:

- 1 Check to make sure that all cabinet pins are properly installed. Engage the hoist to lift the array off the ground. As the hoist lifts, each cabinet will expand to the correct angle.

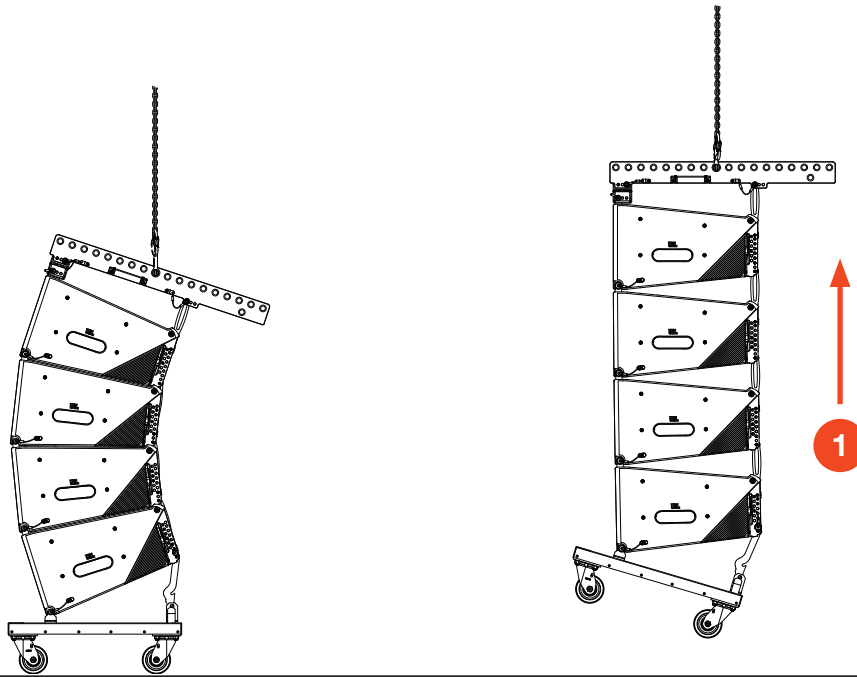

- 2 With the array suspended a short distance off the ground, insert the stop pins into the corresponding STOP PIN holes for the top three cabinets of the stack.

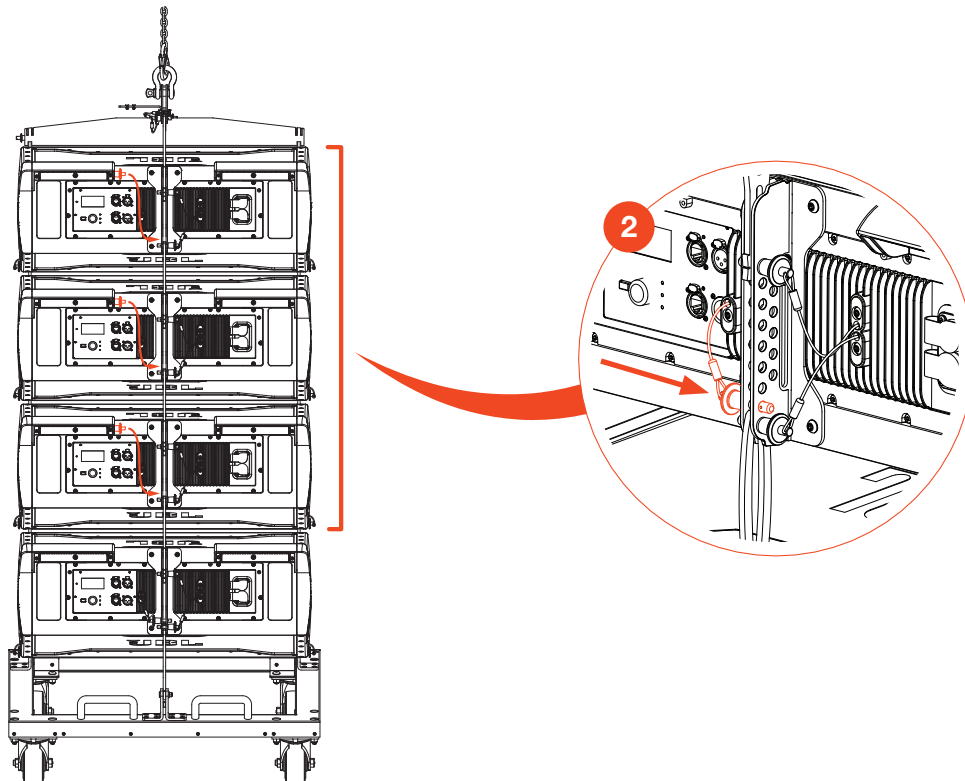

STEPS (Continued):

- 3 Disconnect the Vertical Transporter or Case bottom by removing the front two pins, allowing the front wheels of the cart to touch the ground.
- 4 Remove the bottom STOP Pin and place it in the handle.
- 5 Unhook the rear mounting arm of the VT or Case and remove the LINK pin.

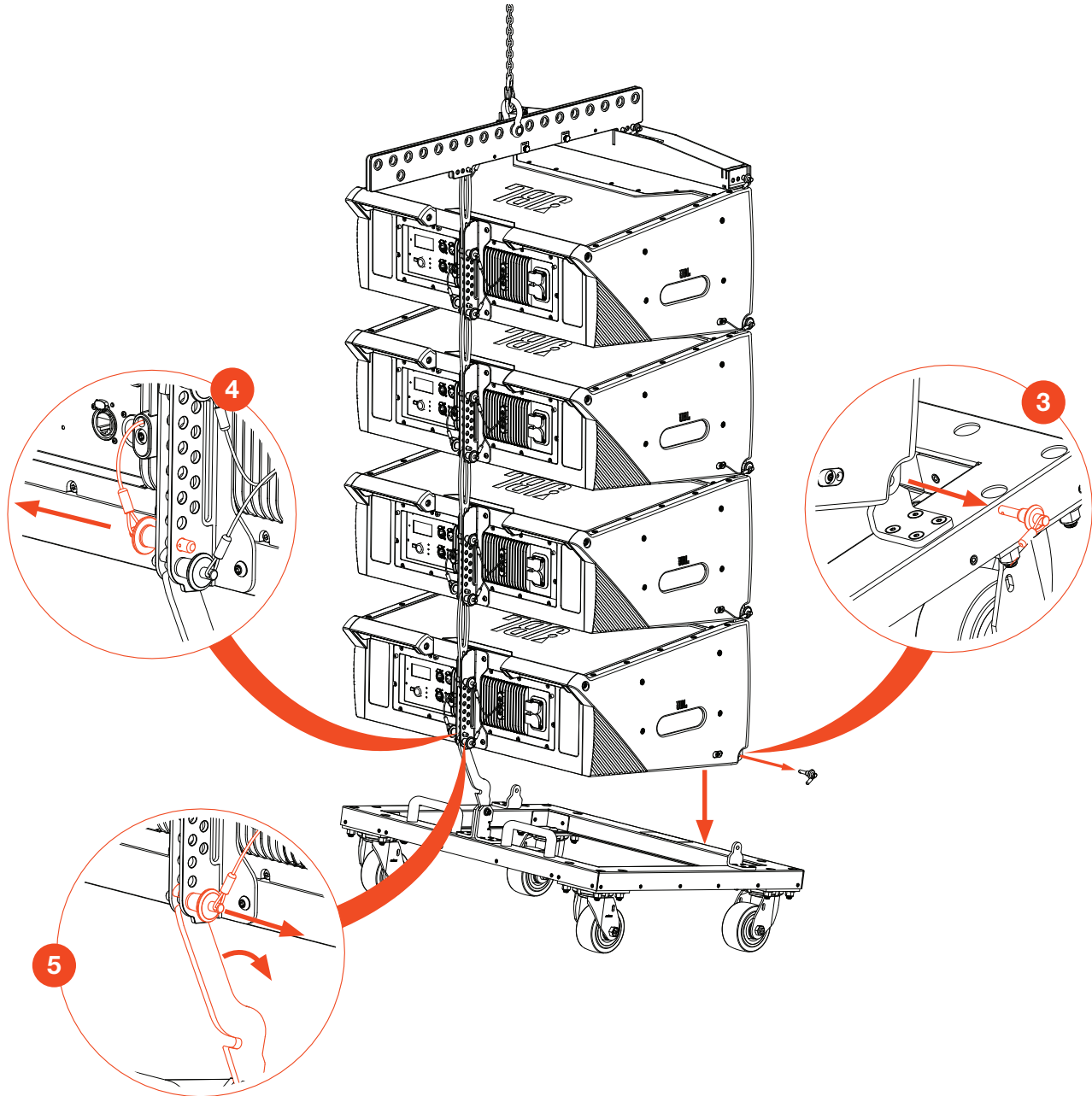

9.4 ATTACH THE NEXT STACK

STEPS:

- 1 Follow the steps in **Section 9.1 Set the Angles for the First Set of Cabinets** to set the angles of the next stack of SRX9xxLA cabinets.
- 2 Raise the suspended cluster and align the next set of cabinets below.
- 3 Lower the suspended cluster until the front attachment points make contact.
- 4 Insert the two front quick release pins to secure the stacks together.

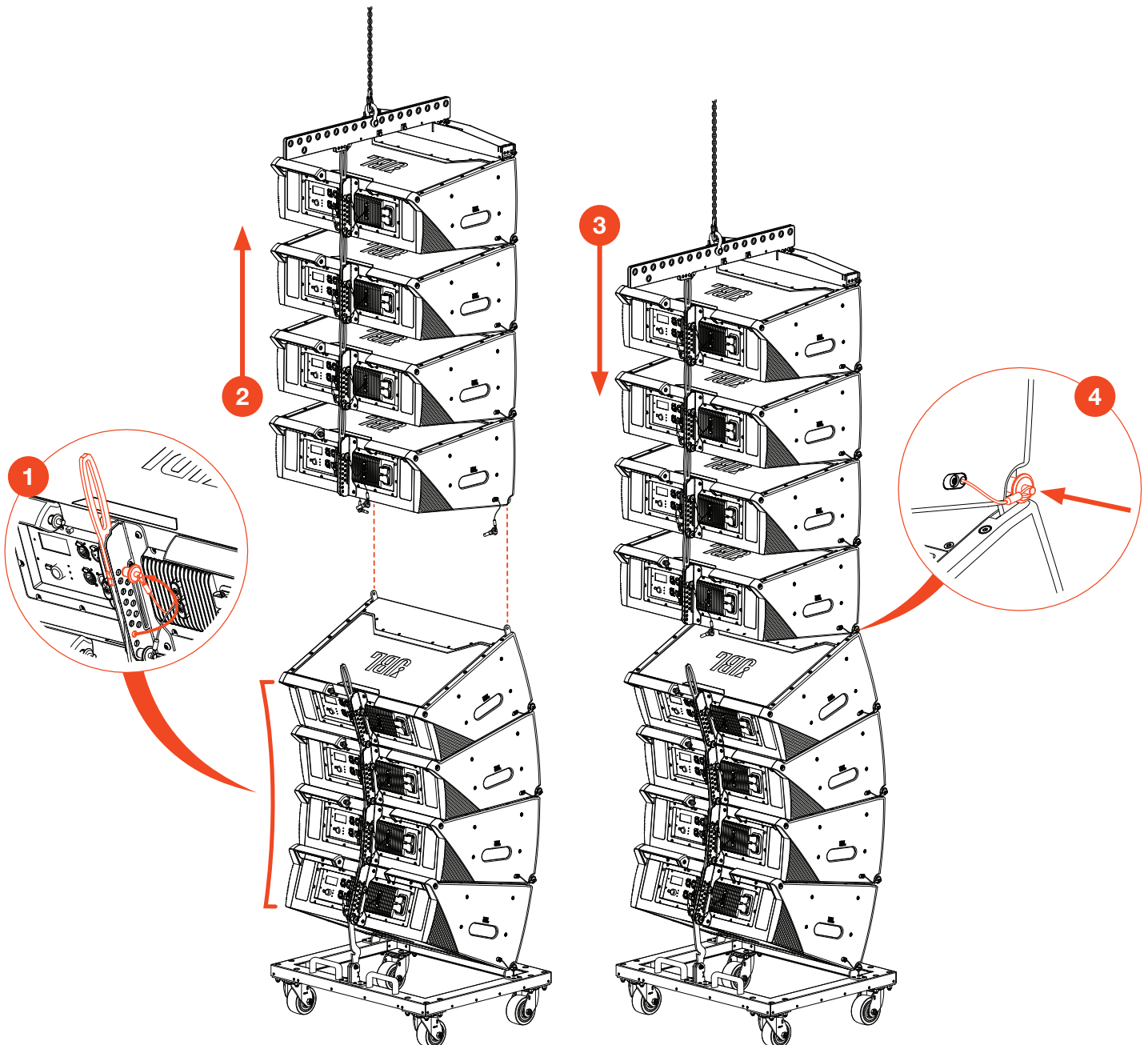

STEPS (Continued):

- 5 Use the electric hoist to raise the array. Be aware that the lower cluster may swing forward as it lifts off the ground.
- 6 Insert the stop pins of the top three cabinets of the lower stack.
- 7 Grab the lower cluster by the rear handlebar and gently pull back towards the rear of the array. While doing this, lower the array until the front wheels touch the ground.
- 8 Continue lowering the array until the rear attachment points draw close together and the link pin can be inserted.
- 9 Lift the array off the ground, insert the stop pin between the fourth and fifth cabinets up from the ground, and remove the VT or Case.

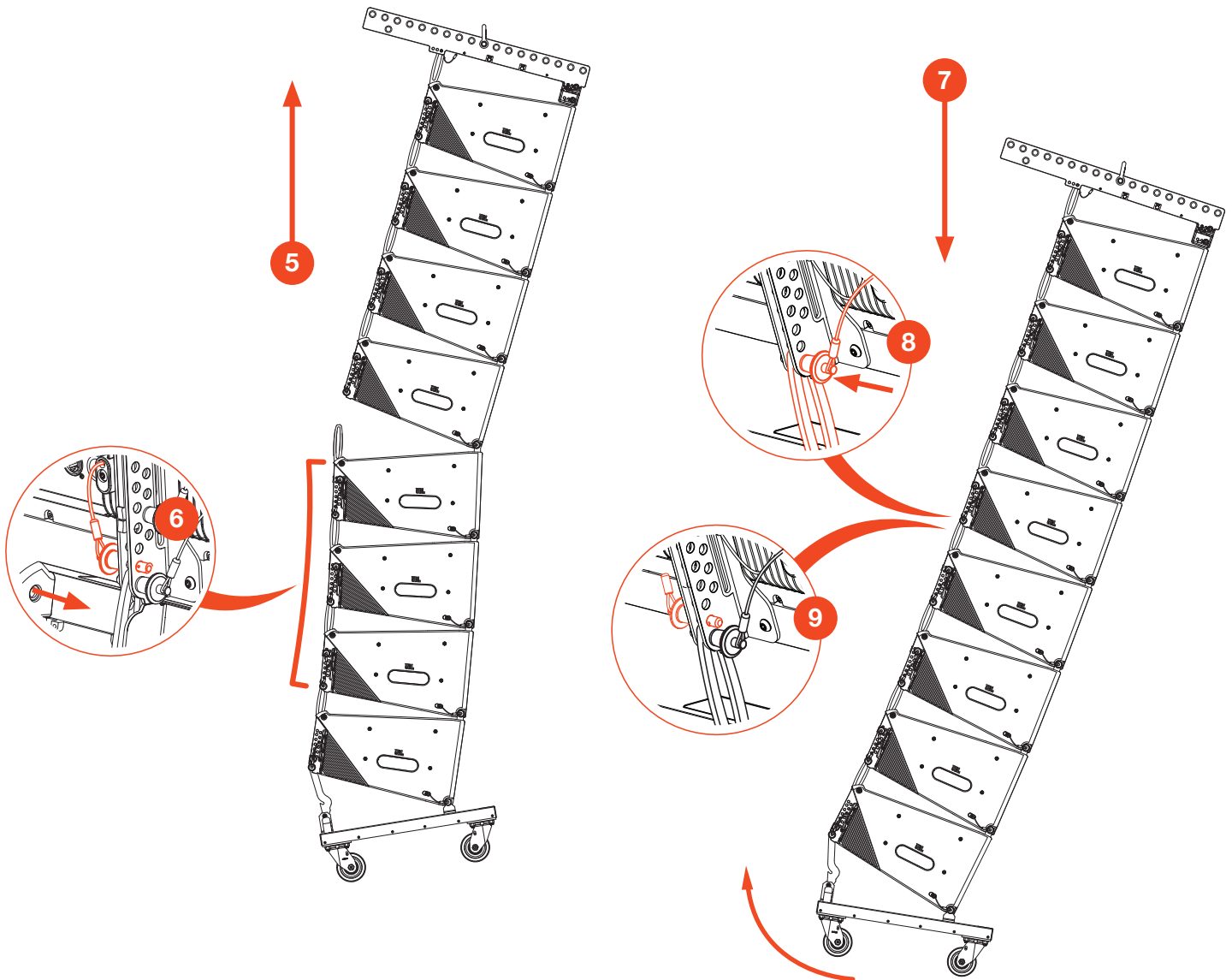

9.5 REPEAT UNTIL COMPLETED

Repeat the steps in **Section 8.4** until the entire array has been assembled.

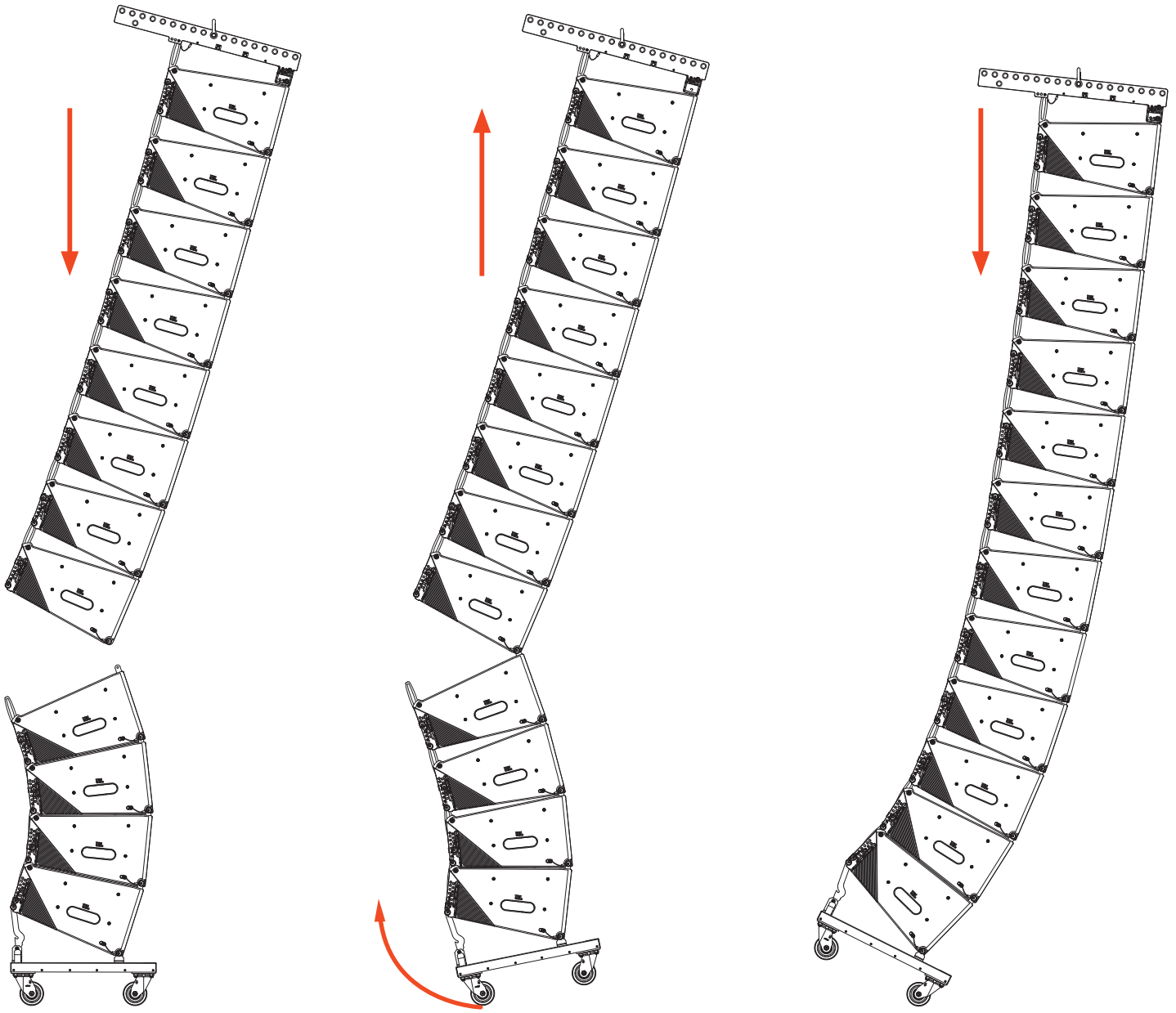

10 - DISASSEMBLING AN ARRAY

Follow the steps in this chapter to safely disassemble an array of SRX900LA cabinets. Although an SRX910LA is pictured in the chapter, the same steps should be followed for an SRX906LA array.

10.1 LOWER THE ARRAY AND REMOVE THE STOP PINS

STEPS:

- 1 Safely lower the array to a workable height.
- 2 Remove the stop pin from the bottom five cabinets and install them into their storage position in the handle. This enables the bottom four cabinets to collapse back to the 12° position once the array is lowered to the ground.
- 3 Attach the VT or Case to the bottom cabinet. Hook the rear arm to the bottom cabinets, install the stop pin, then lift the front side of the VT or Case and attach the front two points.

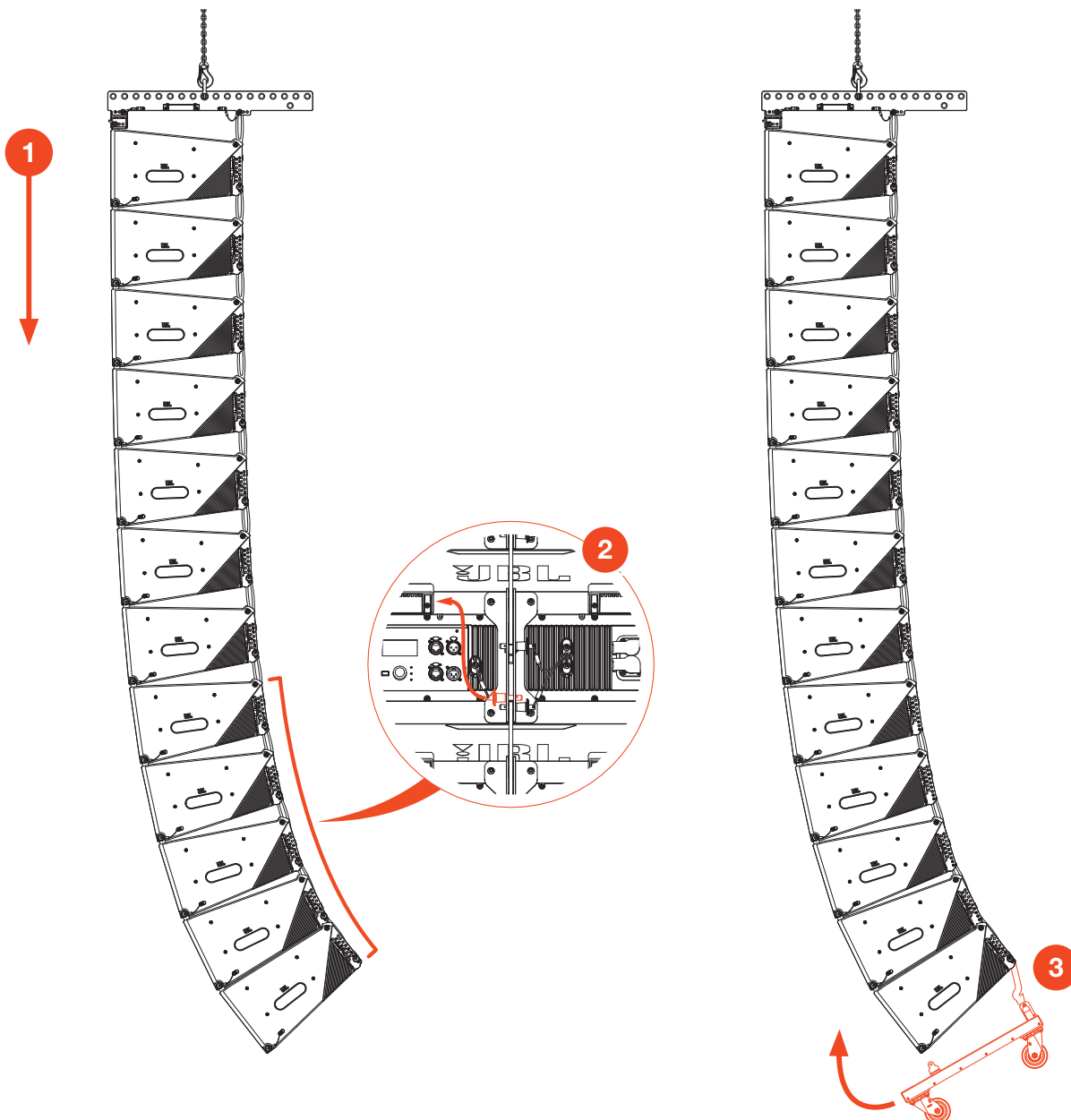

10.2 COLLAPSE THE ARRAY AND MOVE THE PINS TO THE STORAGE POSITION

STEPS:

- 1 Lower the array until the front wheels touch the ground. The array should start to roll backwards and, as the array is lowered, the cabinet-to-cabinet angles of the bottom five cabinets will close to the 12° position.
- 2 Once the lowest four boxes are entirely collapsed, and the gap between the fourth and fifth cabinets (from the bottom) is closed, work from the bottom cabinet up and set the link bars of the lowest four cabinets to the 12° STORAGE position.
- 3 Remove the rear link pin from the fifth cabinet. This pin should move easily, as the weight of the array is being held by the front wheels of the VT or Case resting on the ground.
- 4 Raise the array and allow the four cabinets to roll forward until the cart is resting safely on all four wheels.
- 5 Remove the front pins and separate the suspended array from the stack on the VT cart.

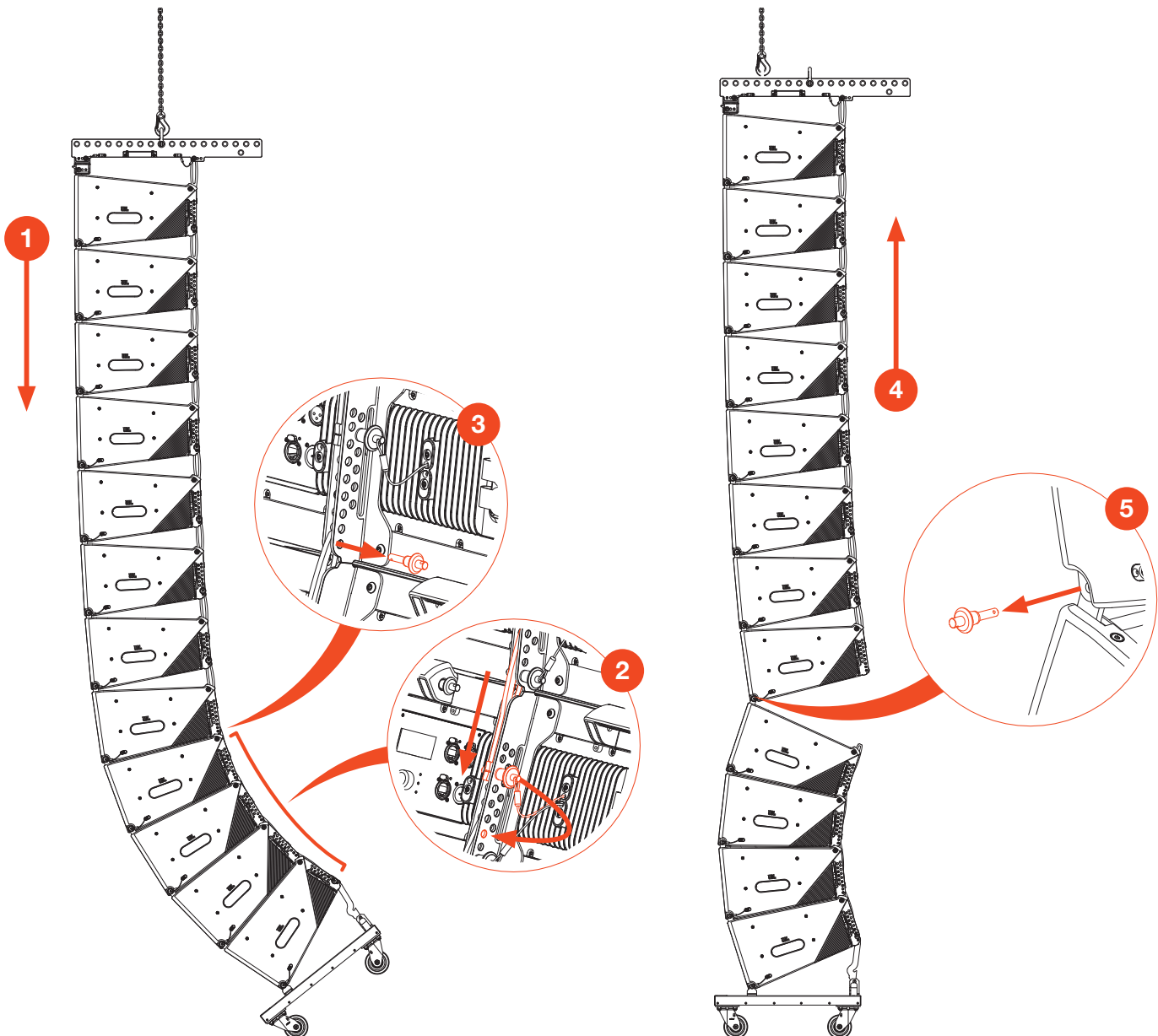

10.3 REPEAT STEPS TO DISCONNECT THE NEXT FOUR CABINETS

Repeat the previous steps to disconnect and store the next four cabinets of the array.

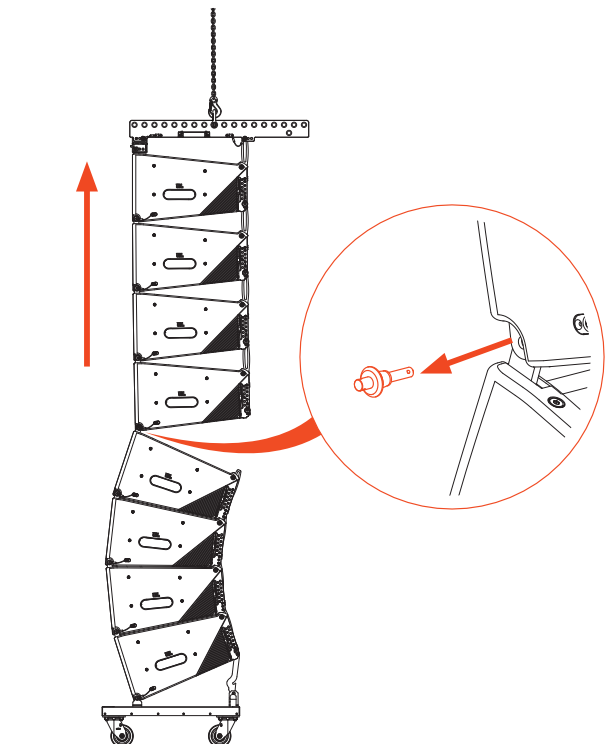
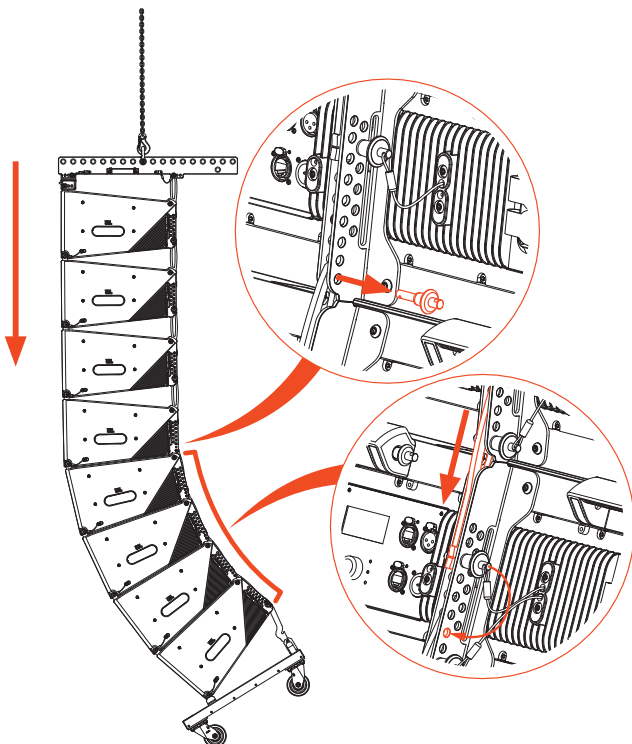
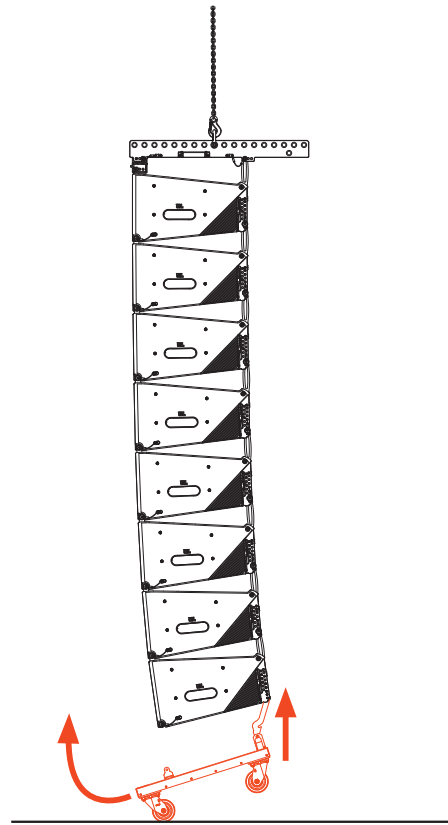
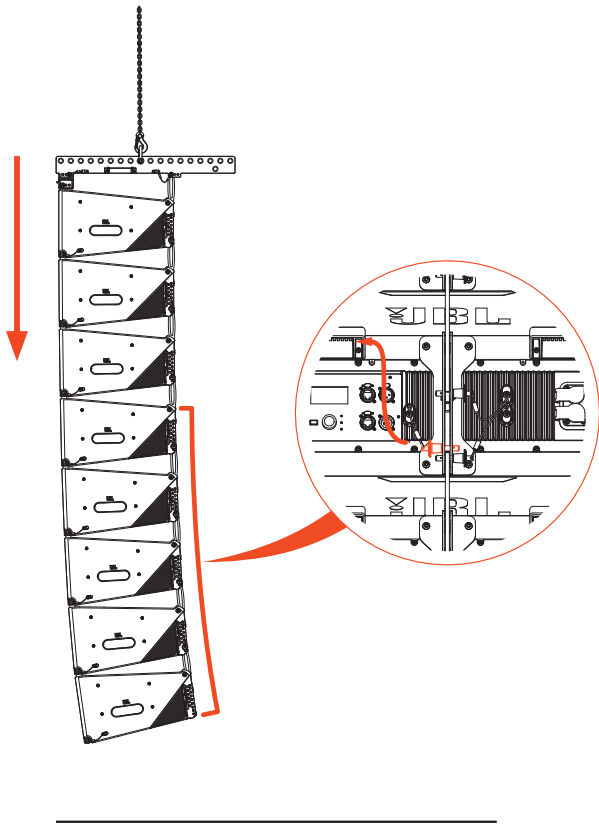

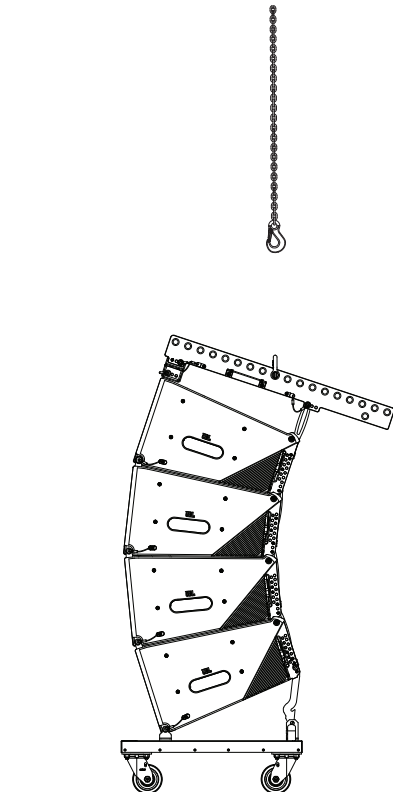
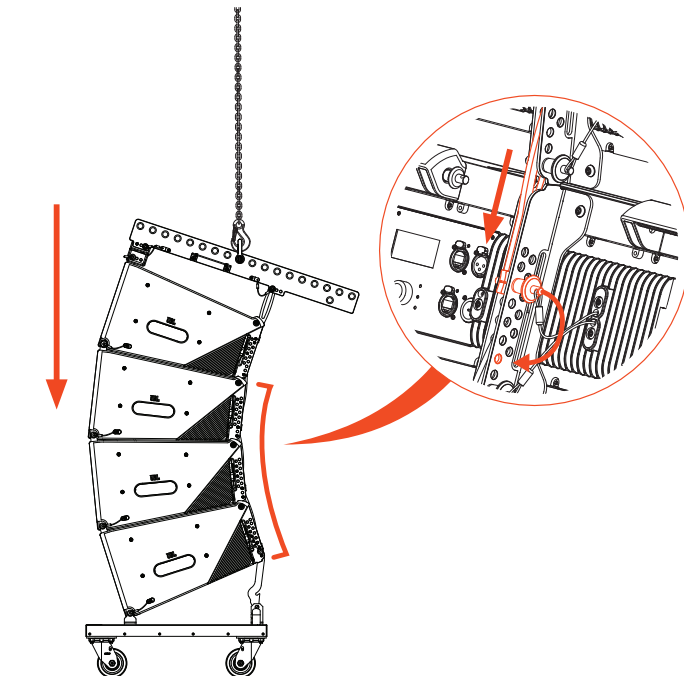
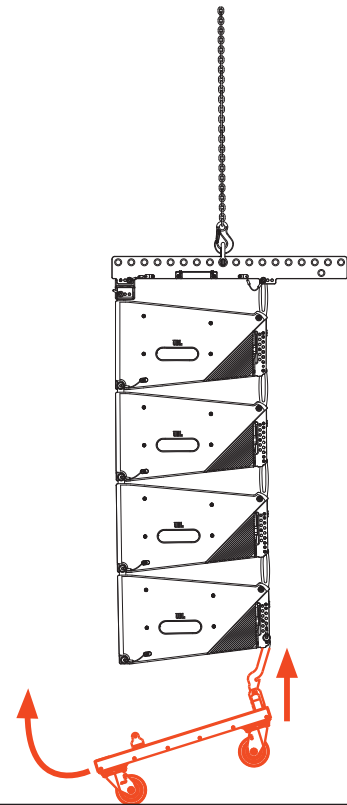
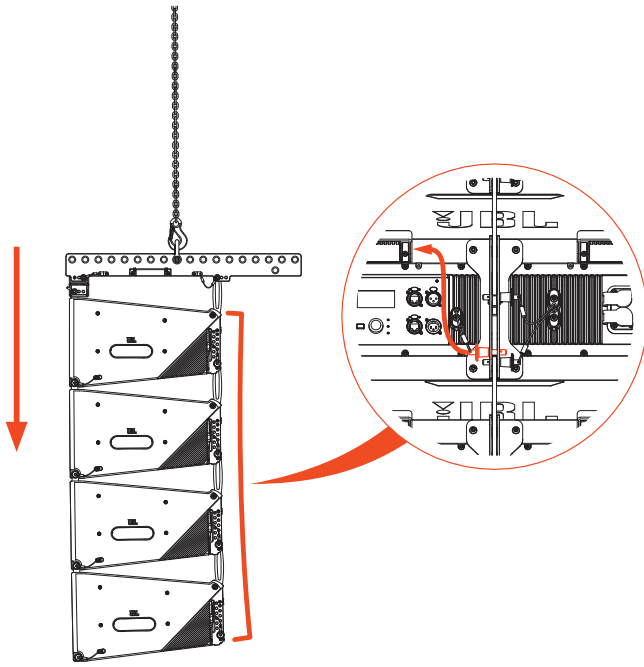

11 - DEPLOYING SUBWOOFER ARRAYS

SRX900SF Subwoofers can be flown in standalone or mixed configuration arrays. The SRX915SF is mechanically compatible with the SRX906LA and the SRX918SF is mechanically compatible with the SRX910LA. The same Array Frames that are used with the SRX-900LA products are used to suspend the matching SRX900SF Subwoofer.

11.1 ATTACHING THE ARRAY FRAME TO THE FIRST SUBWOOFER

STEPS:

- 1 Deploy the front two connection Bars, consult **Section 5.4 Deploying the SRX900SF Front Connection Bars**.
- 2 Place the spreader bar on the top cabinet between the front two connection points and insert the pins. Consult Venue Synthesis software to determine whether the A, B, or C position is used. Ensure that both sides are pinned in the same position.
- 3 Pin the extension bar to the spreader bar using the two pins provided. Consult Venue Synthesis for proper orientation. Ensure that both pins are used to secure the two pieces together.
- 4 Flip up the rear link bar of the cabinet and pin it to the extension bar. Make sure to use the same A, B, or C position used in Step 2.
- 5 Attach the 1/2-inch shackle to the correct hole on the extension bar and connect the hoist.

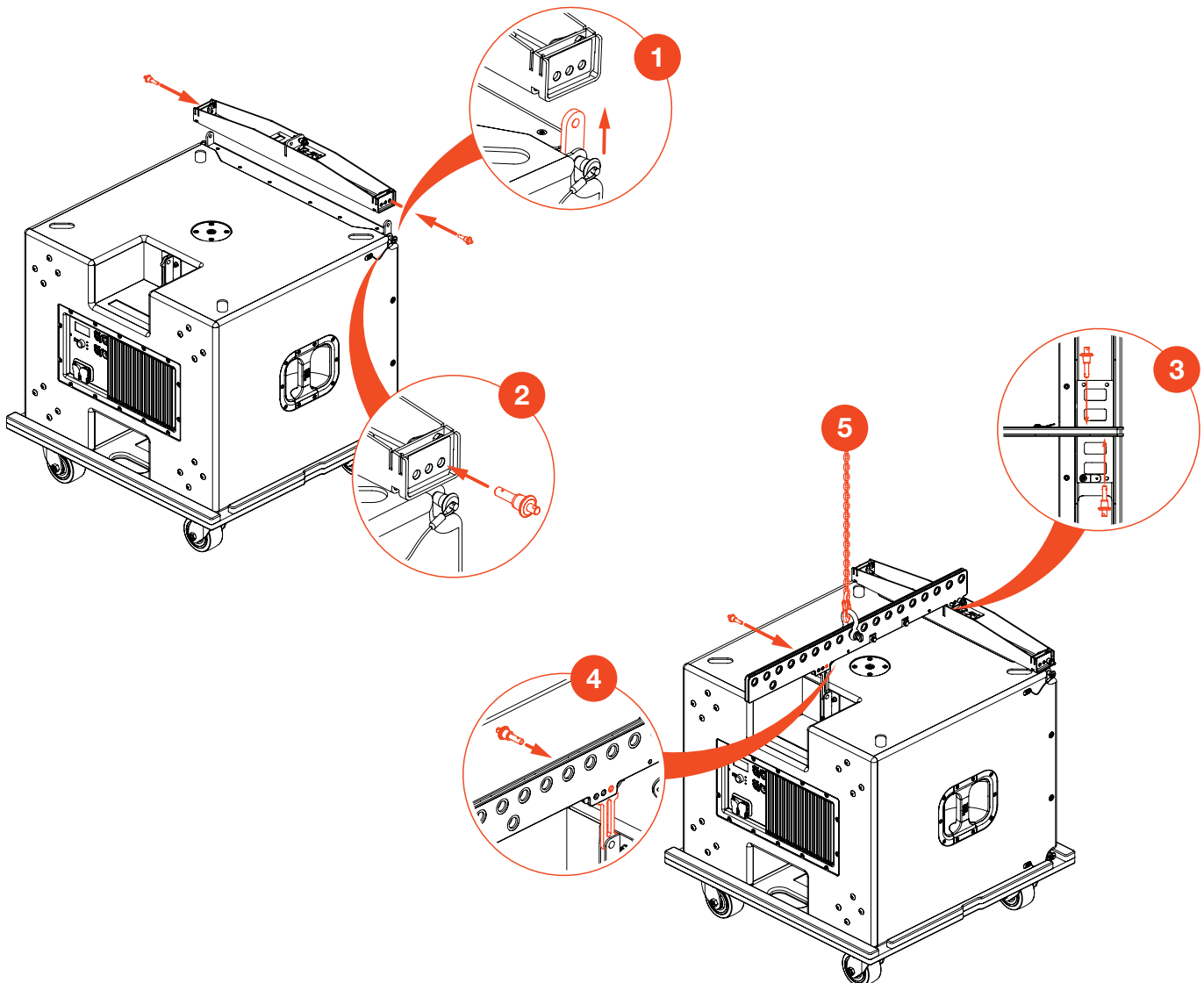

11.2 ATTACHING ADDITIONAL SUBWOOFERS

STEPS:

- 1 Use the electric hoists to raise the first SRX900SF off the ground.
- 2 Remove the Front Attachment Pins, and the rear Link and Stop Pins from the flown subwoofer.
- 3 Position the next subwoofer on the ground beneath the flown subwoofer and deploy the Front Connection Bars as described in **Section 5.4 Deploying the Front Connection Bars**.
- 4 Land the flown subwoofer on top of the ground subwoofer making sure to align the front connection points and insert the Front Attachment Pins.

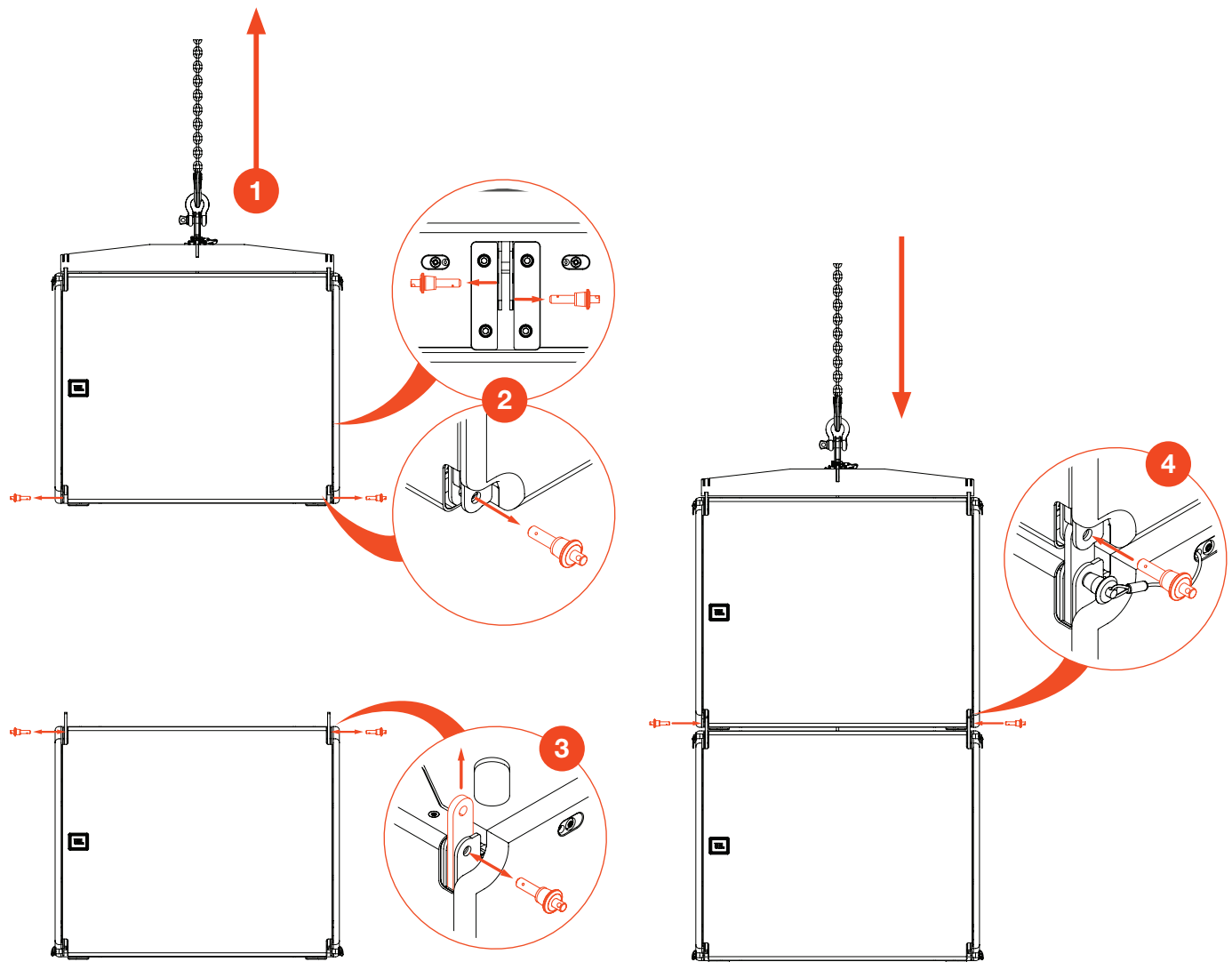

STEPS Continued:

- 5 Flip up the lower subwoofer Rear Connection Point and connect it to the upper subwoofer using the Link Pin.
- 6 Lift the subwoofer array.
- 7 Insert the Stop Pin into the upper subwoofer.

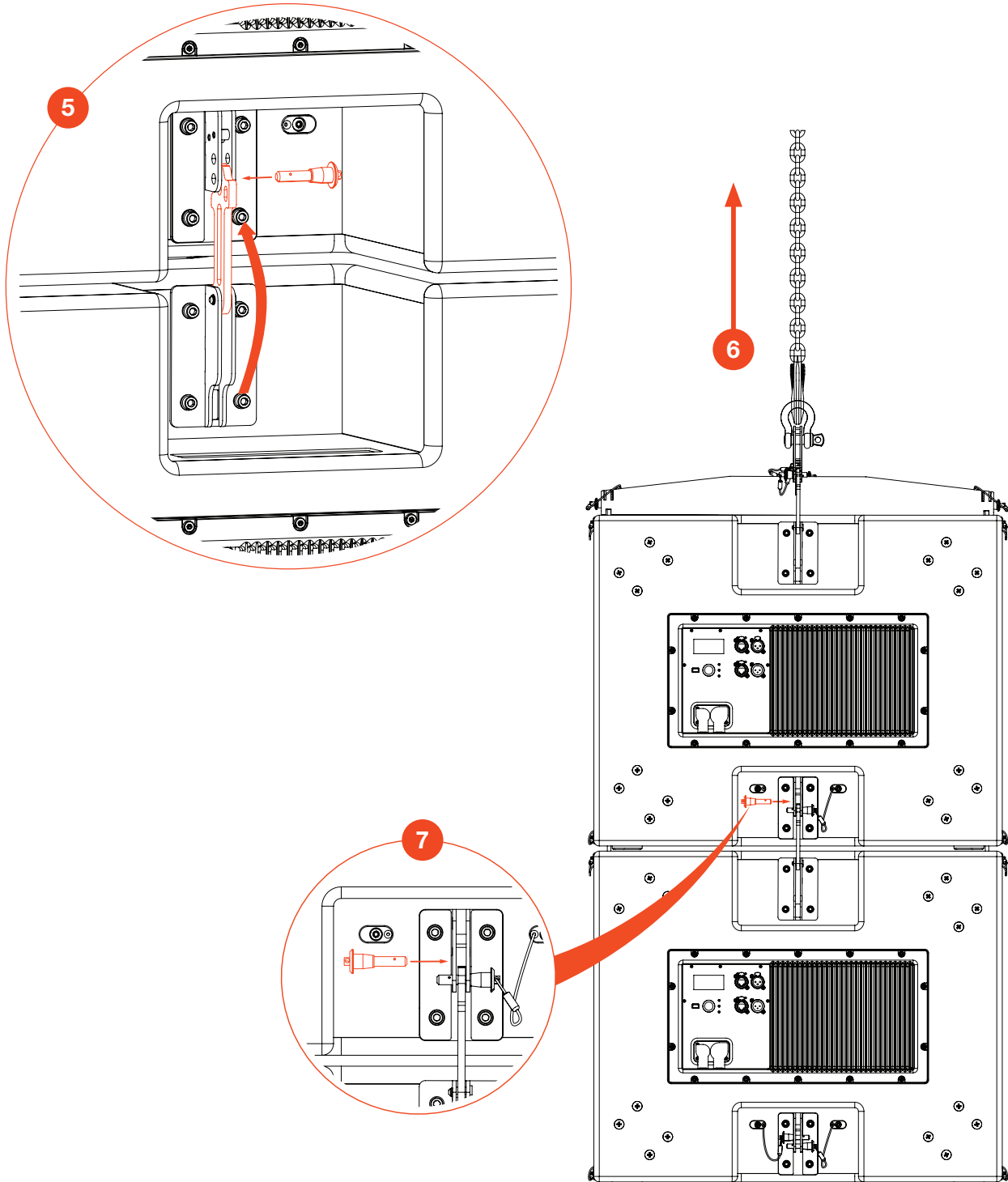

11.3 SUSPENDING MIXED ARRAYS

With the subwoofers suspended, compatible SRX900LA speakers can be suspended below to create mixed arrays.

STEPS:

- 1 Follow the procedures detailed in **Section 8.1 - Set the Angles for the First Set of Cabinets** to prepare the first set of compatible SRX900LA cabinets for suspension.
- 2 Raise the subwoofer array and remove the Front Attachment Pins and the rear Link and Stop Pins from the bottom subwoofer.
- 3 Align the SRX900LA cabinets below the subwoofer array and lower the array until the front attachment points make contact.
- 4 Re-insert the two Front Attachment Pins to secure the stacks together.

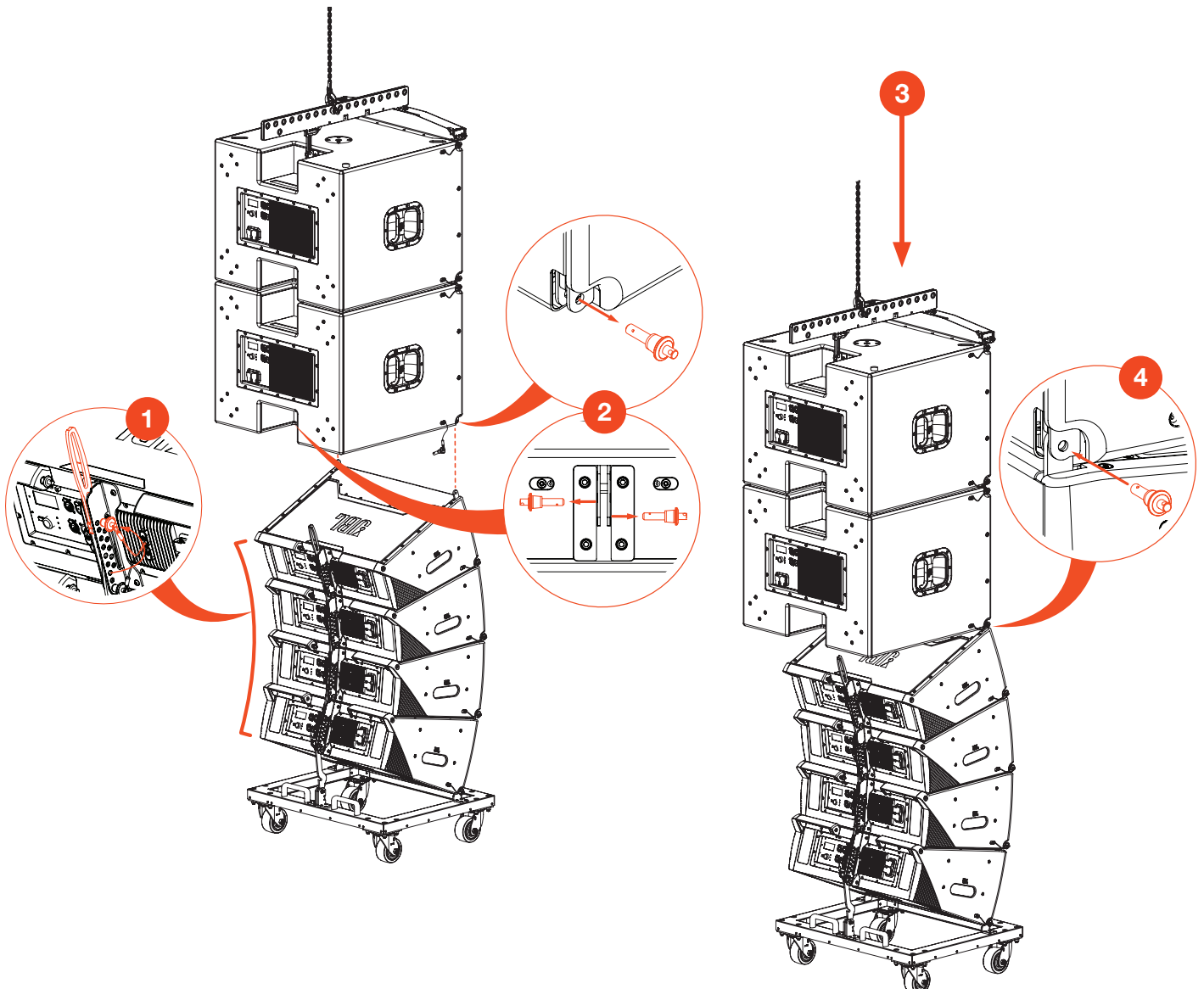

STEPS (Continued):

- 5 Use the electric hoist to raise the array. Be aware that the lower cluster may swing forward as it lifts off the ground.
- 6 Insert the Stop Pins into the top three cabinets of the SRX900LA Cabinets.
- 7 Grab the SRX900LA stack by the rear handlebar of the Case or VT and pull backwards while simultaneously lowering the array until the front wheels touch the ground.
- 8 Continue lowering the array until the rear attachment points draw close together and the link pin can be inserted.
- 9 Lift the array off the ground, and insert the STOP Pin into the lowest subwoofer then remove the VT or Case.
- 10 Follow steps in **Section 8.4 - Attach the Next Stack** to continue adding SRX900LA speakers to the array.

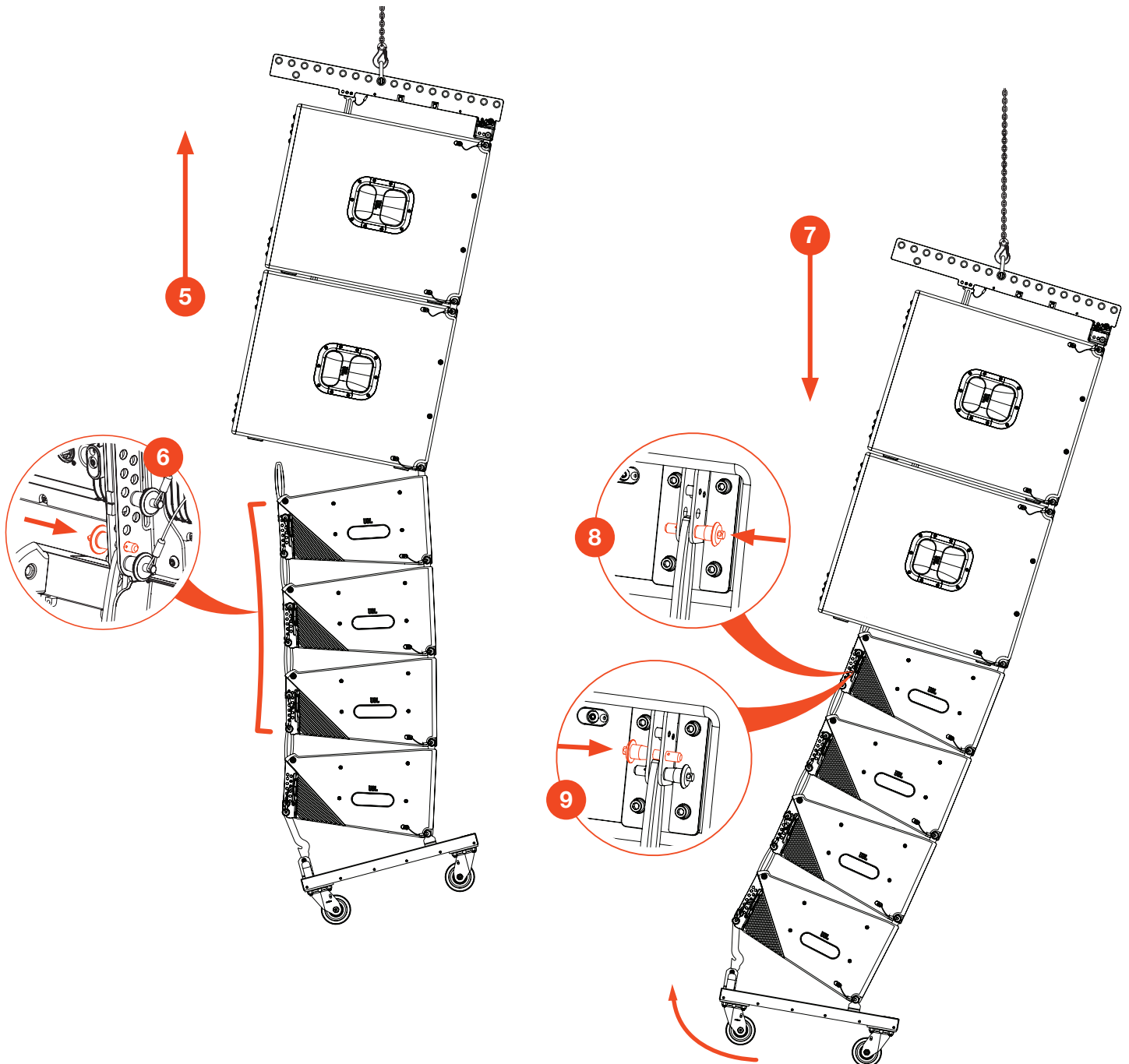

11.4 DE-RIGGING MIXED ARRAYS

The steps to de-rig a mixed array are very similar to an SRX900LA only array. Follow the steps in **Section 9 – Disassembling an Array** to safely remove all clusters of SRX900LA cabinets EXCEPT the stack connected to the subwoofer(s), then proceed with the steps below.

STEPS:

- 1 Remove the Stop Pins from the top three SRX900LA Cabinets and the STOP pin from the bottom flown subwoofer.
- 2 Attach the VT or case bottom to the lowest SRX900LA cabinet in the mixed array.
- 3 Lower the array until the case or VT wheels touch the ground, continue lowering the array until the bottom three SRX900LA cabinets have fully collapsed and the top SRX900LA cabinet's Link Bar is no longer under tension on the subwoofers Link Pin.
- 4 Reset the Angle selection pins of the bottom three SRX900 cabinets to the Storage Position. **Do not reset the Angle Selection pin of the top SRX900LA cabinet in the stack.**
- 5 Remove the rear Link Pin from the lowest subwoofer in the Array. If this pin does not move freely it may be necessary to continue lowering the Array until tension is relieved.

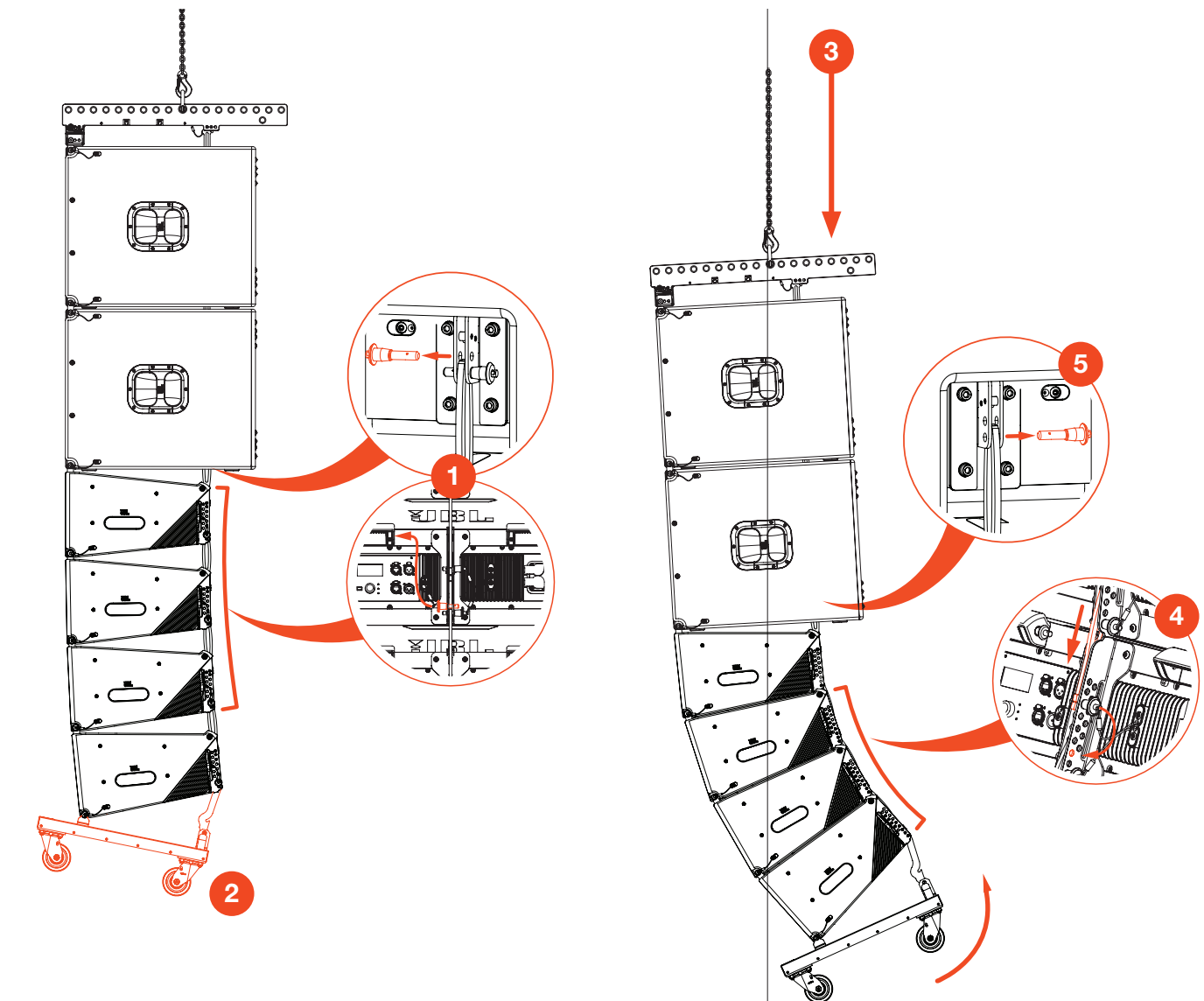

STEPS Continued:

- 6 Raise the array and allow the four cabinets on the Case or VT to roll forward until the cart is resting safely on all four wheels.
- 7 Remove the front pins and separate the suspended subwoofer array from the stack on the VT cart.
- 8 Re-insert the pins into the bottom subwoofer for storage.

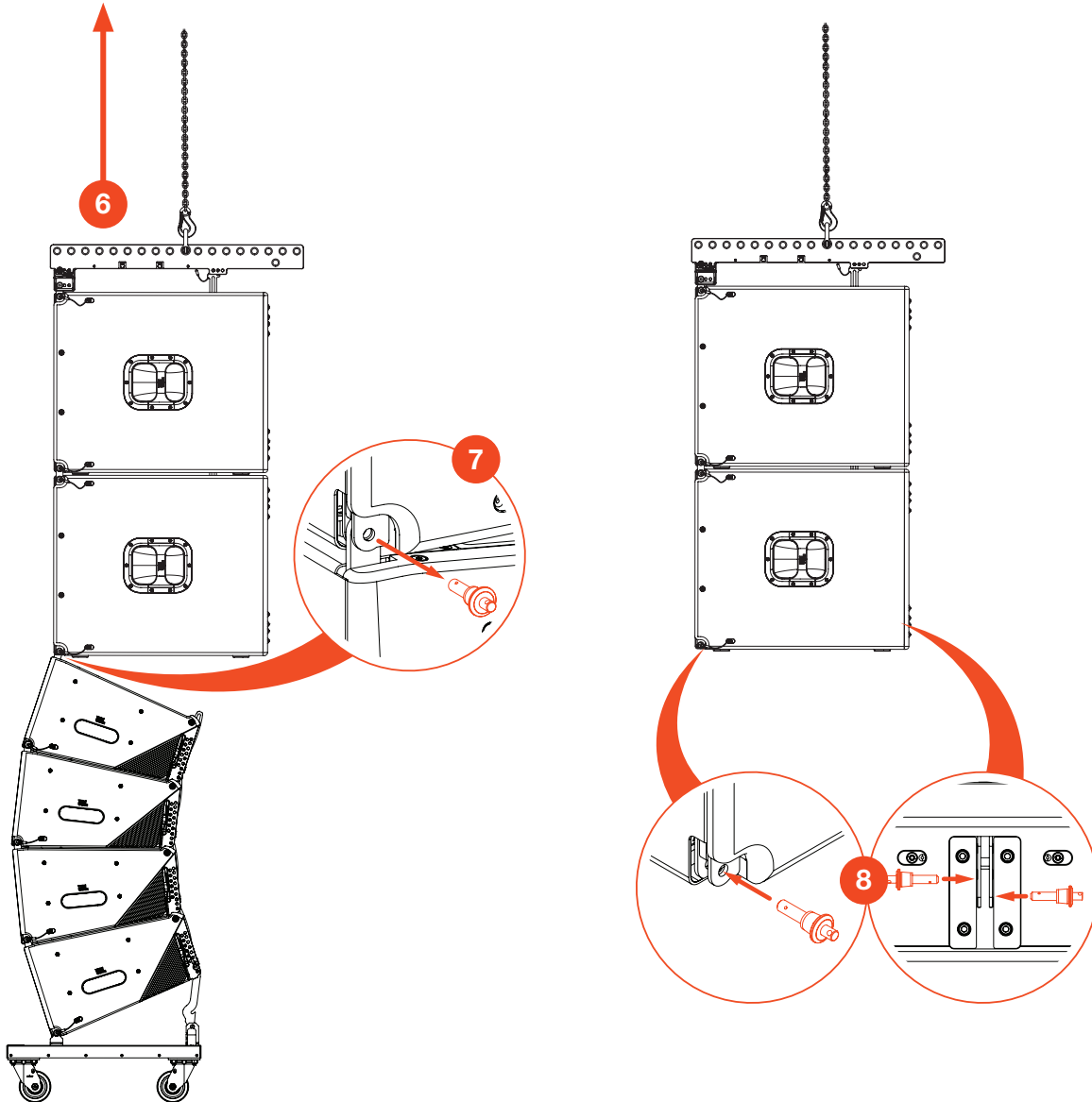

11.5 DE-RIGGING FLOWN SUBWOOFERS

Arrays of subwoofers can be disconnected individually or in blocks of two or three subwoofers by following the instructions below. When disconnecting blocks of multiple subwoofers, the array can be landed directly on a matching VT cart to make transporting the stack of subwoofers easier.

STEPS:

- 1 Remove the stop pin from the subwoofer above the highest subwoofer being disconnected.
- 2 Land the subwoofer array on the ground.
- 3 Remove the rear Link Pin and Front Connection Pins from the subwoofer above the highest subwoofer being disconnected.

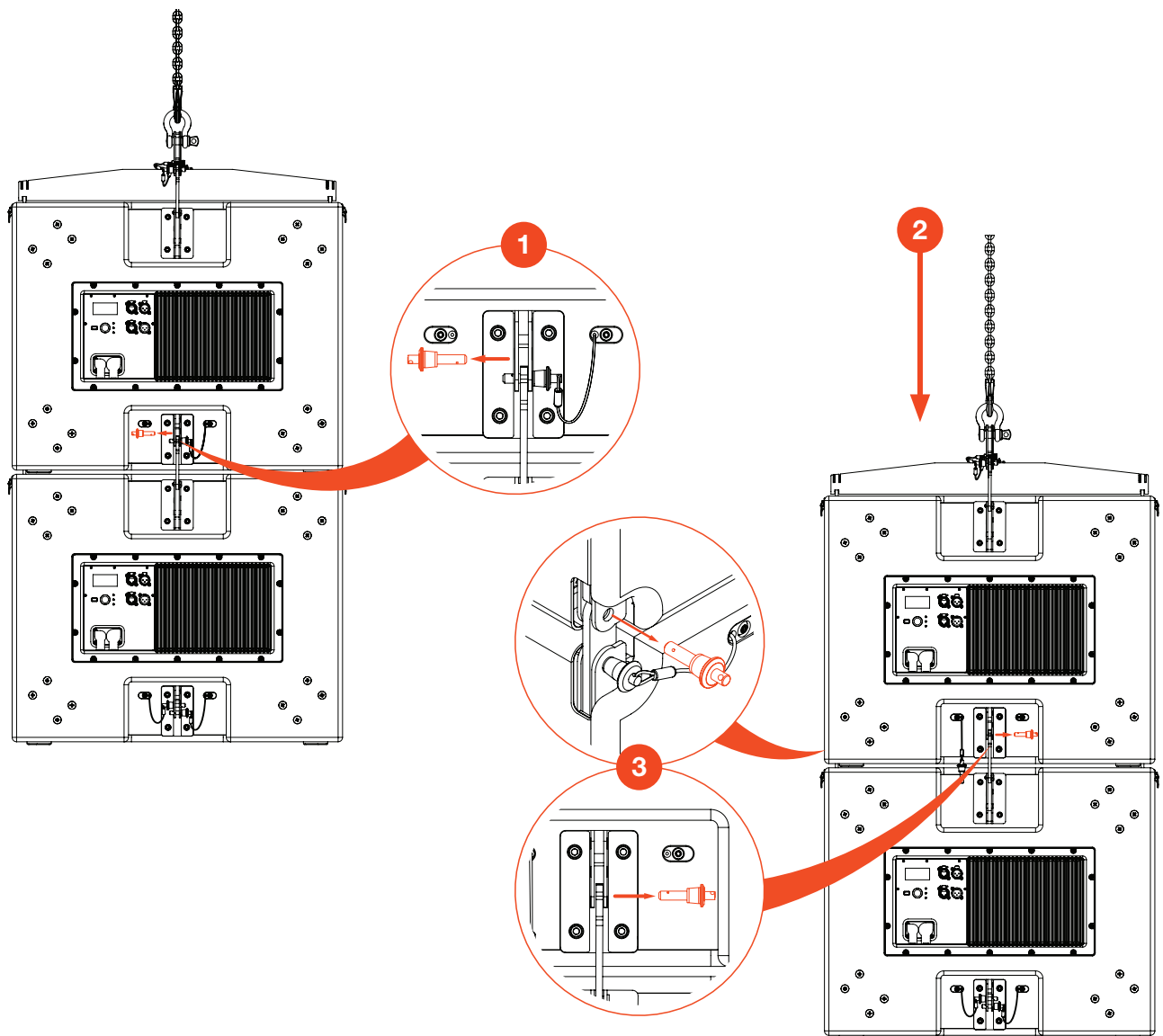

TIP: Flown subwoofer cabinets can be landed directly on top of their corresponding Vertical Transport (VT) carts in blocks of 2 or 3 cabinets high with the rigging still connected to save time.

STEPS Continued:

- 4 Raise the remaining suspended subwoofer array and remove the disconnected cabinet(s).
- 5 Return the Front Connection Bars to the storage position on the disconnected subwoofer.
- 6 Re-insert the pins on the lowest subwoofer remaining in the array and repeat the above steps for the remaining subwoofers.

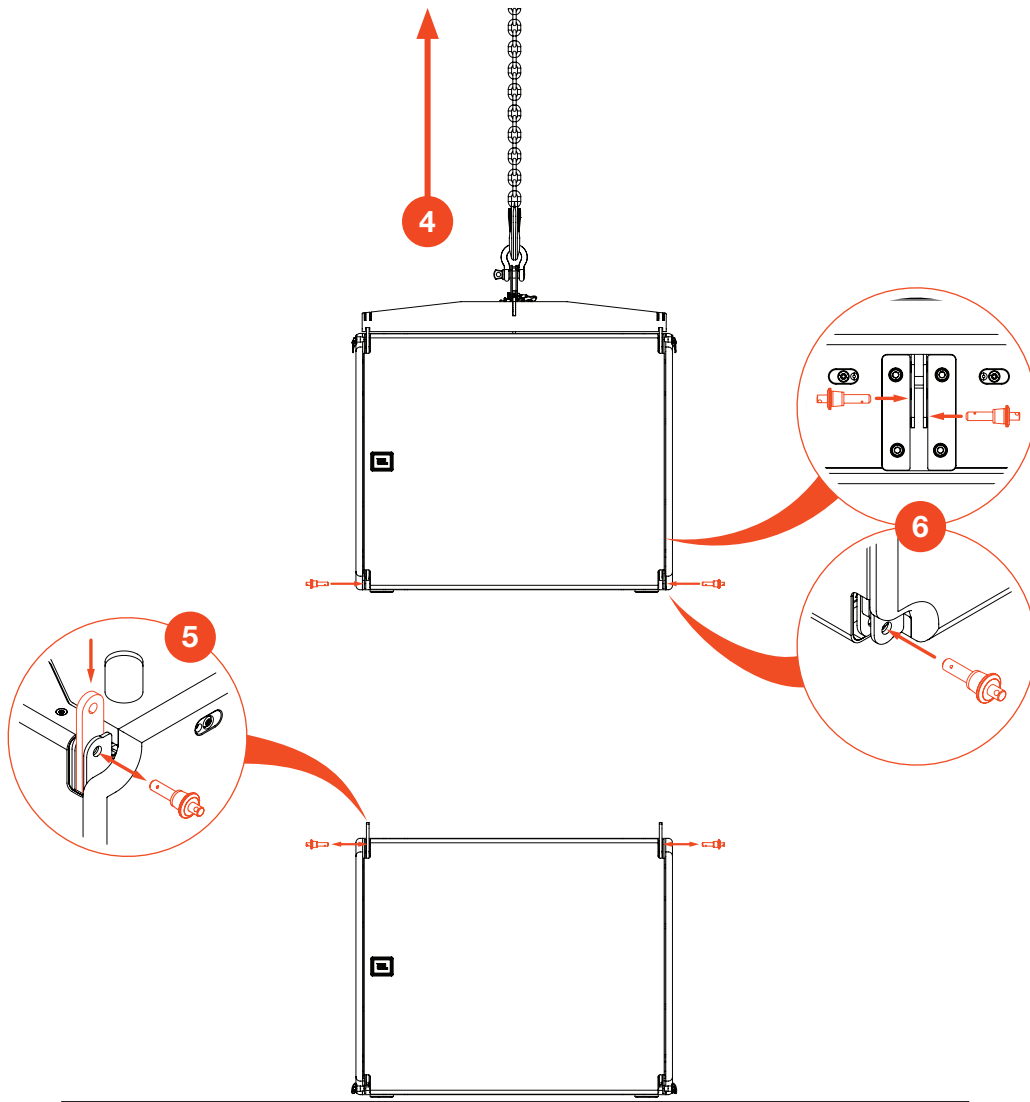

12 - PULL-BACK

The SRX900LA PB is a pull-back attachment for configurations requiring a significant amount of downtilt. With the array frame connected to the primary suspension point at the top of the array, the SRX900LA PB connects to the bottom of the array and is lifted by a second motor point at the rear of the array. The two motors are adjusted to achieve the desired array downtilt.

12.1 DEPLOYING ARRAYS USING A PULL-BACK

STEPS:

- 1 Follow the steps in **Chapter 8 - Deploying Arrays** to suspend the array using the hoist attached to the array frame.
- 2 Insert the pin at the LINK position to attach the SRX900LA PB to the lowest cabinet in the array.
- 3 Attach the hoist to the shackle position of the SRX900LA PB and lift the array to the desired downtilt angle .

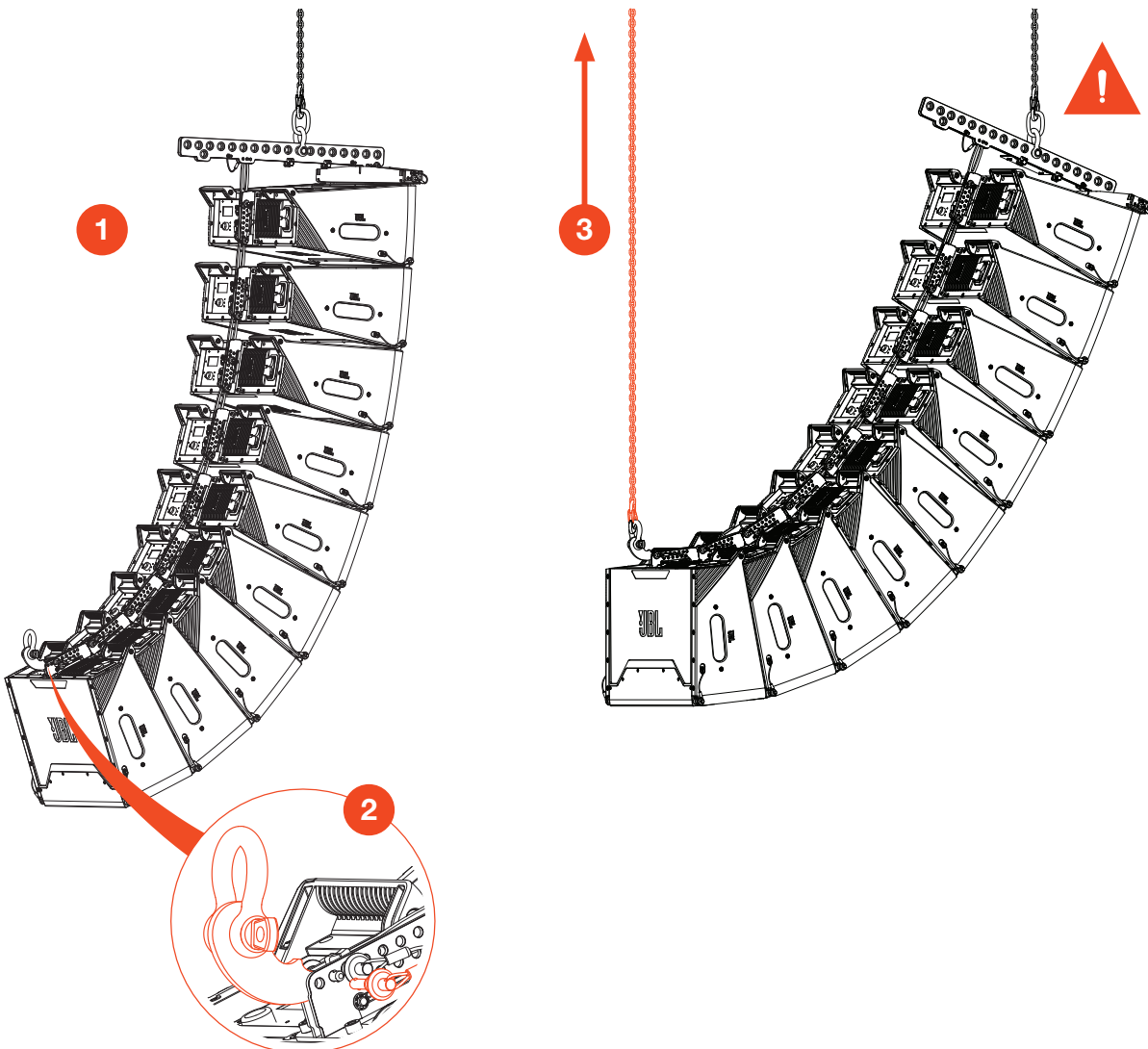

CAUTION: When using the SRX900LA PB, never attach a motor hook to the shackle directly connected to the array frame as the hook can bind against the frame. Always space the hook off the frame using deck chain or additional shackles.



CAUTION: The SRX900LA PB pull-back accessory cannot be used with SRX900SF standalone arrays due to interference between the chain and the last cabinet of the array.

12.2 WHEN TO USE A PULL-BACK

The use of a pull-back is common when the center of gravity (CoG) of an array falls outside the footprint of the array frame. Typically, long curved arrays with a large downtilt qualify for this condition. When this occurs, Venue Synthesis displays an error to indicate that the array frame alone cannot achieve the down angle needed for the design (Example 1 - No pull-back). Using an SRX900LA PB will shift the array CoG between the two suspension points, enabling almost any down angle to be achieved (Example 2 - With pull-back).

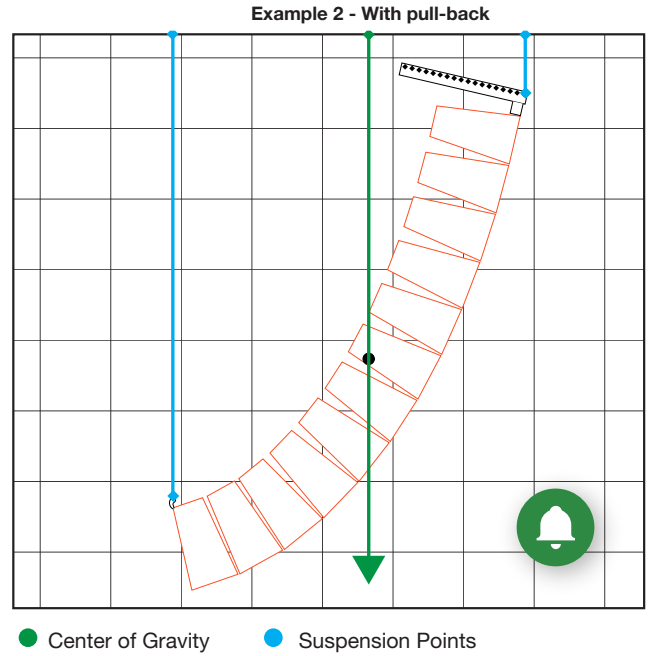
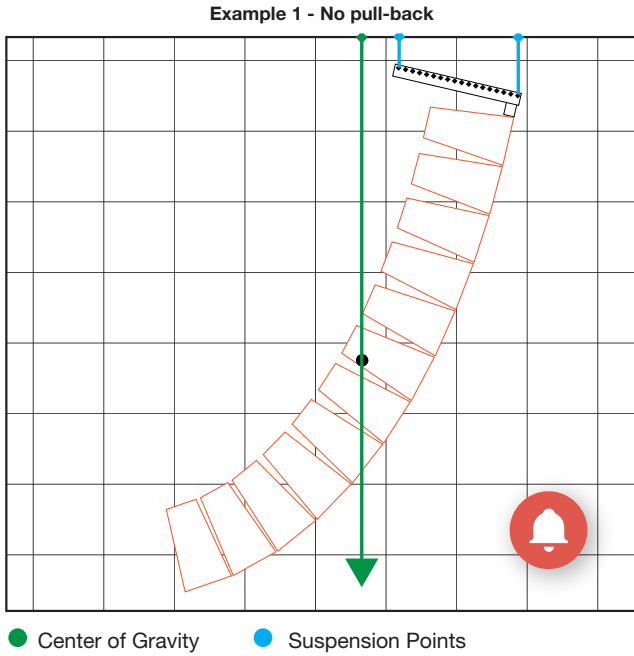

CAUTION: All SRX900 Series systems should be designed and validated using Venue Synthesis software, this is the only way to ensure that safe mechanical conditions are met for any given configuration.

13 - BASE PLATES

The SRX906LA BP Base Plate and the SRX910LA BP Base Plate are universal adapter frames that enable arrays to be ground stacked on top of compatible subwoofers or support structures such as stages, scaffolding, or carts. Using the included M20 screw, a base plate connects to supported subwoofers equipped with a standard M20 pole mount adapter, such as the SRX900S or SRX900SF models. The base plate attaches directly to the bottom of the cabinets, and the rear angle selection bar allows for angles ranging from -15 to +5 degrees. When not used with subwoofers, M10 through-holes can be used to permanently attach an array to other support structures. The base plates include one 50 mm wide (2 in) notch on each side for easy use with ratchet straps. Configurations and load conditions for using a Base Plate can be obtained using the Venue Synthesis software.

13.1 BASE PLATE OVERVIEW

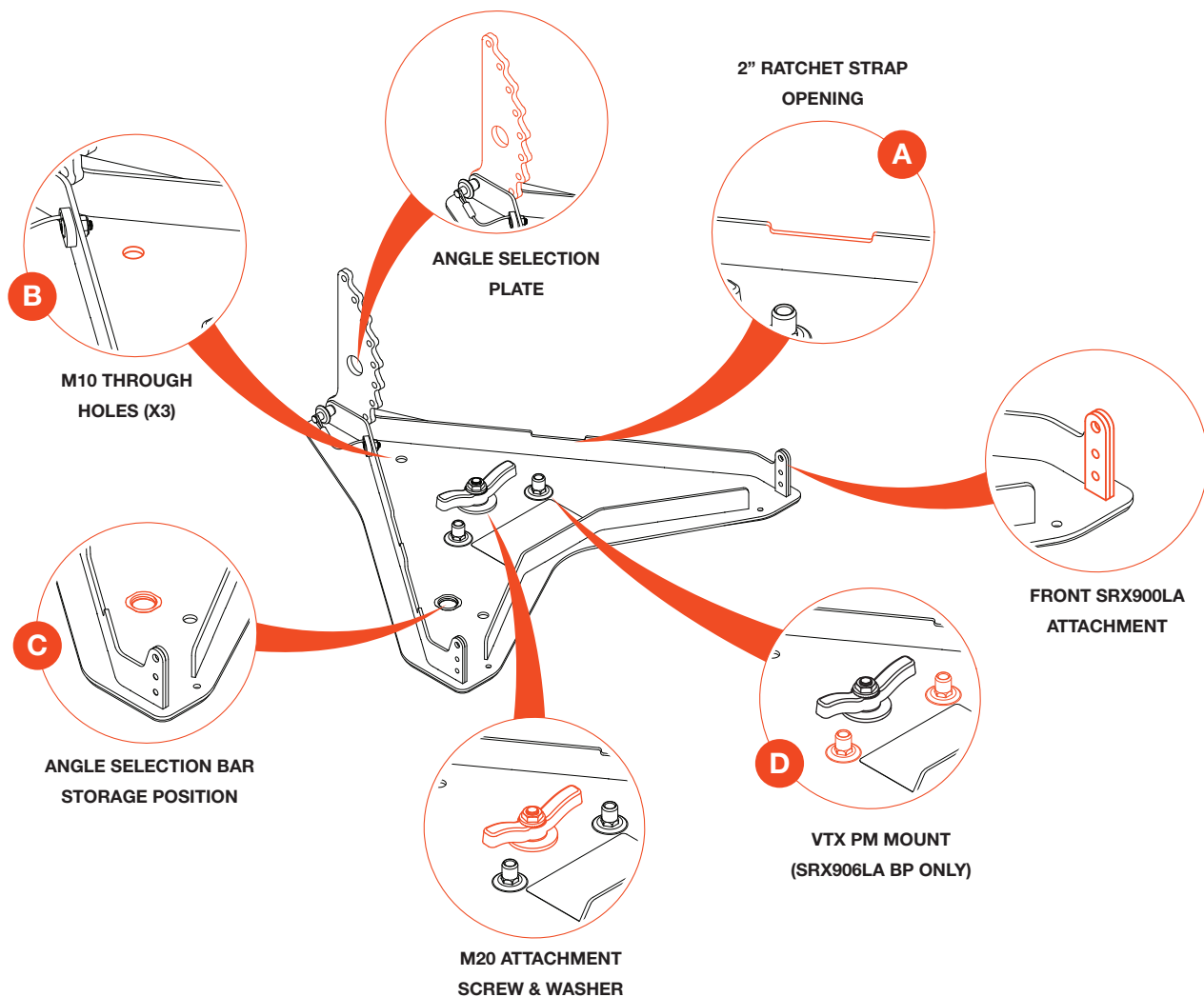

NOTES:

- A** A ground-stacked array can be kept from tipping by securing it to a structure with a 2-inch ratchet strap.
- B** Three M10 holes allow the base plate to be secured onto a fixed structure in permanent installations.
- C** Storage position for the angle selection bar. Use M20 knob to secure.
- D** Mounting point for VTX PM enables pole mounting of two SRX906LA cabinets (SRX906LA BP Only).

13.2 BASE PLATE STORAGE POSITION

The angle selection plate can be removed from its normal position and placed in a storage location. The M20 knob is used to secure the angle selection plate onto the base plate. SRX910LA BP is pictured below, but a storage position is also available on the SRX906LA BP.

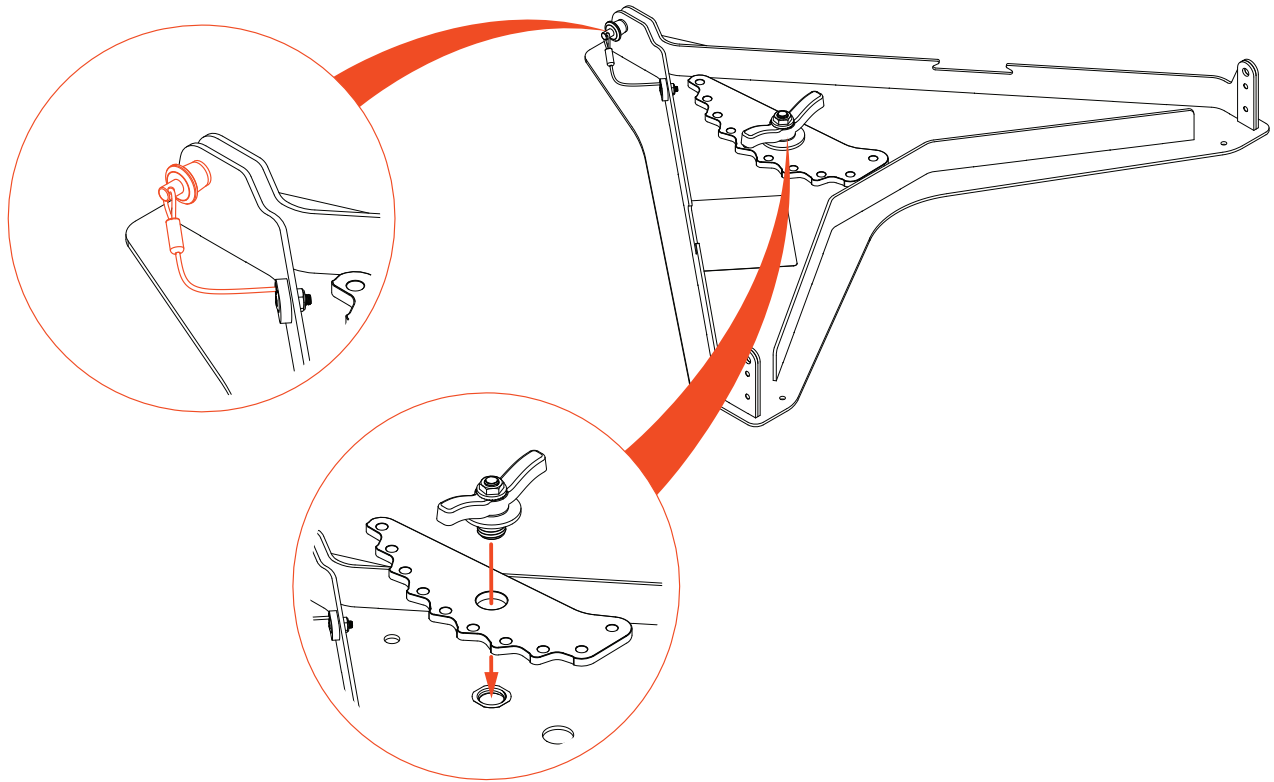

13.3 ANGLE SELECTION PLATE

The base plate angle selection plate includes nine pin positions, allowing for a range of angles from -15 to +5 degrees in 2.5-degree steps. This facilitates selection of the most appropriate position for establishing the required array down angle. JBL Venue Synthesis software is used to determine the best position and check array safety.

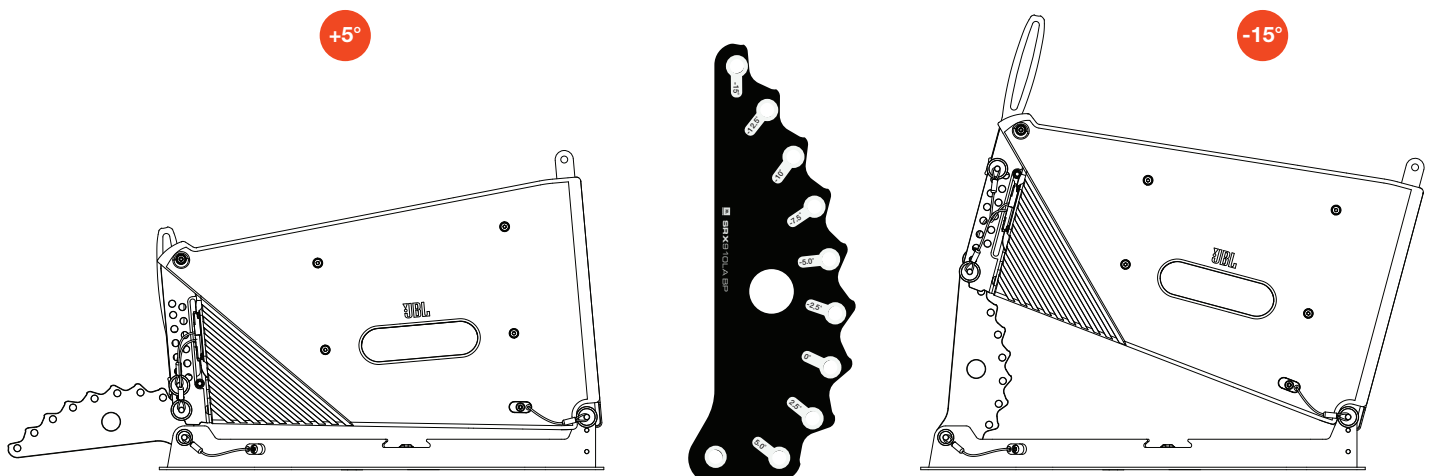

13.4 ASSEMBLING GROUND-STACKED ARRAYS

The base plate attaches to any compatible SRX900 Series subwoofer by the M20 pole mount adapter/plate. Before attaching the base plate, assemble the subwoofer array/stack and place it into the desired location and position. The base plate connects to the subwoofers using the included M20 knob. SRX900 Series cabinets connect to the base plate using the cabinet's front pins, and the link pin in the rear. Follow the instructions below to assemble a ground-stacked SRX900 Series array. The same steps are used regardless of the subwoofer type and SRX9xxLA cabinet used.

STEPS:

- 1 Place the base plate onto the top subwoofer in the array and use the included M20 knob to secure the base plate onto the subwoofer.
- 2 For SRX900S subwoofer stacks more than one cabinet high, secure the cabinets together with a ratchet strap. The strap should wrap around the entire body of both subwoofers, and the webbing of the strap should sit in the laser cut channel on the base plate to prevent it from sliding. SRX900SF subwoofer stacks should be pinned together using the captive rigging.

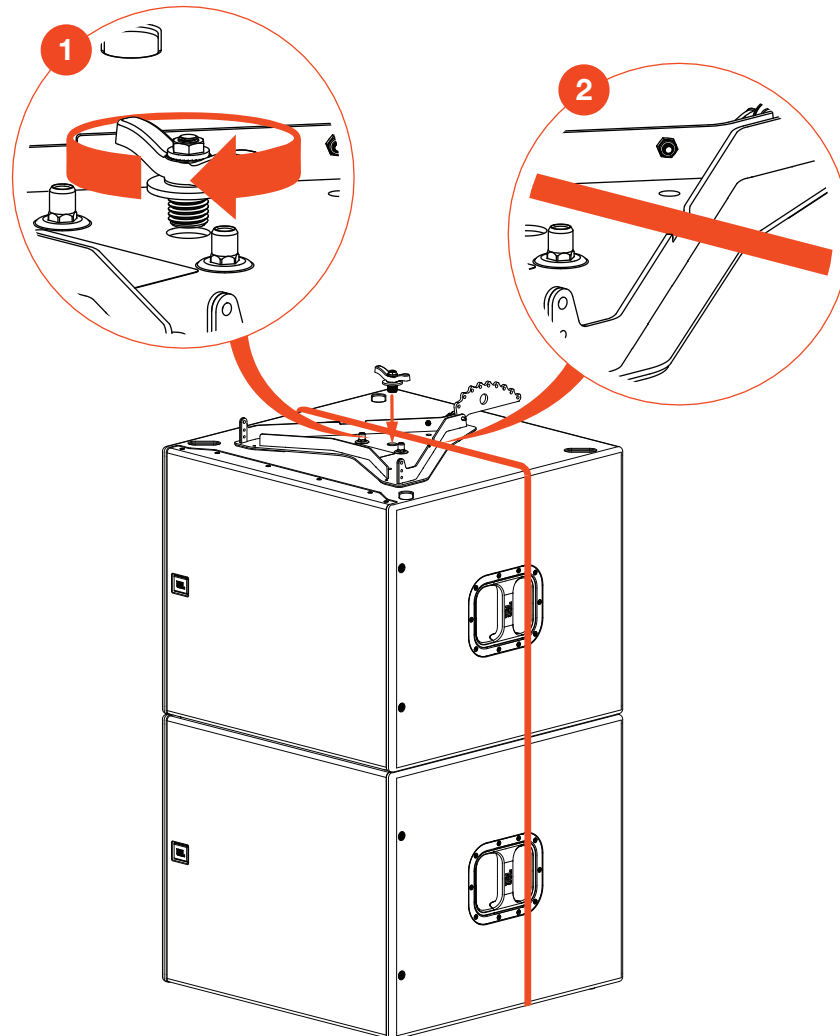

CAUTION: Safe limits for ground-stacked arrays always assume that the stacking surface (floor and/or stage) is flat. Do not deploy ground-stacked arrays on non-flat surfaces to avoid tipping hazards.

STEPS (Continued):

- 4 Remove the link pin and install the stop pin into the angle selection plate of the first SRX9xxLA cabinet.
- 5 Place the first SRX9xxLA cabinet onto the base plate and pin the front two corners using the attached pins.
- 6 Lift the back of the SRX9xxLA and set the base plate's angle selection plate to the desired angle. Pin the SRX9xxLA cabinet and the base plate's angle selection plate using the LINK PIN hole and pin.

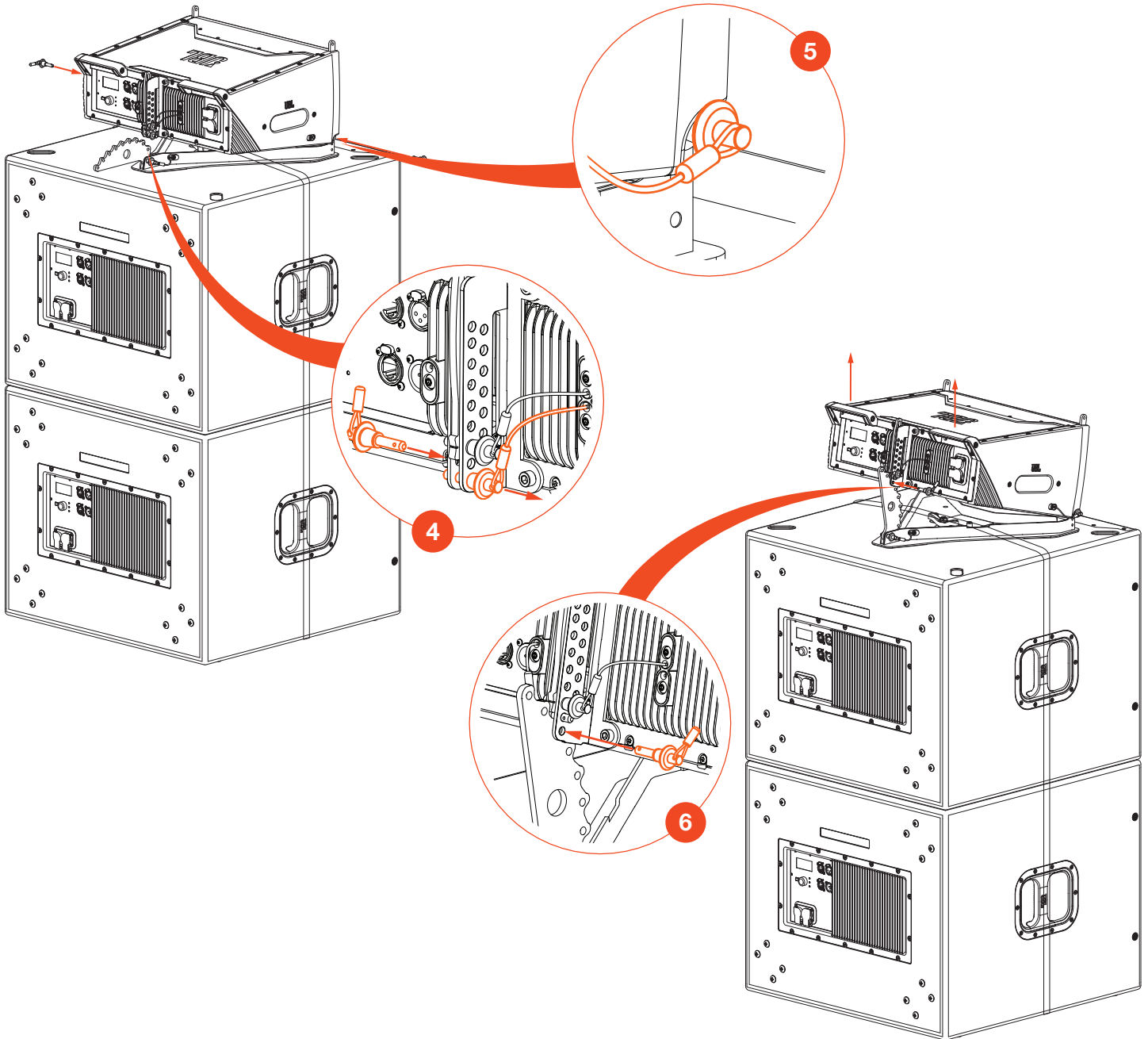

CAUTION: Safe limits for ground-stacked arrays always assume that the stacking surface (floor and stage) is flat. Do not deploy ground-stacked arrays on non-flat surfaces to avoid tipping hazards.

STEPS (Continued):

- 7 Select the desired cabinet-to-cabinet angle for the first SRX900LA enclosure and extend the link bar to that angle. Pin the link bar with the angle selection pin in the corresponding hole of the angle selection plate.
- 8 With its stop pin inserted, stack the next SRX900LA on top, pin the cabinets together, and set the angle for the next cabinet.
- 9 Repeat steps 7 and 8 as needed to assemble the full array.

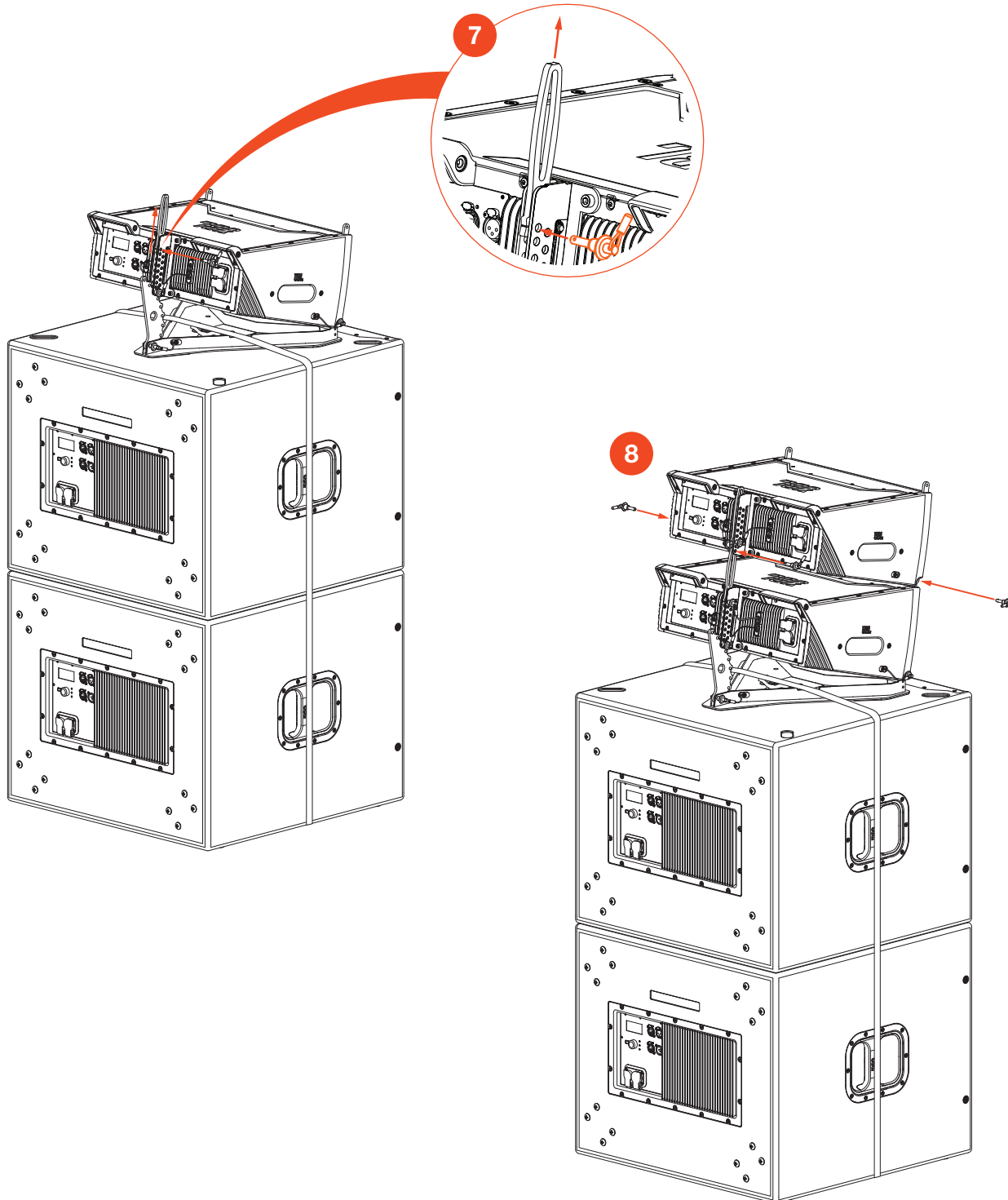

13.5 GROUND STACK EXAMPLES

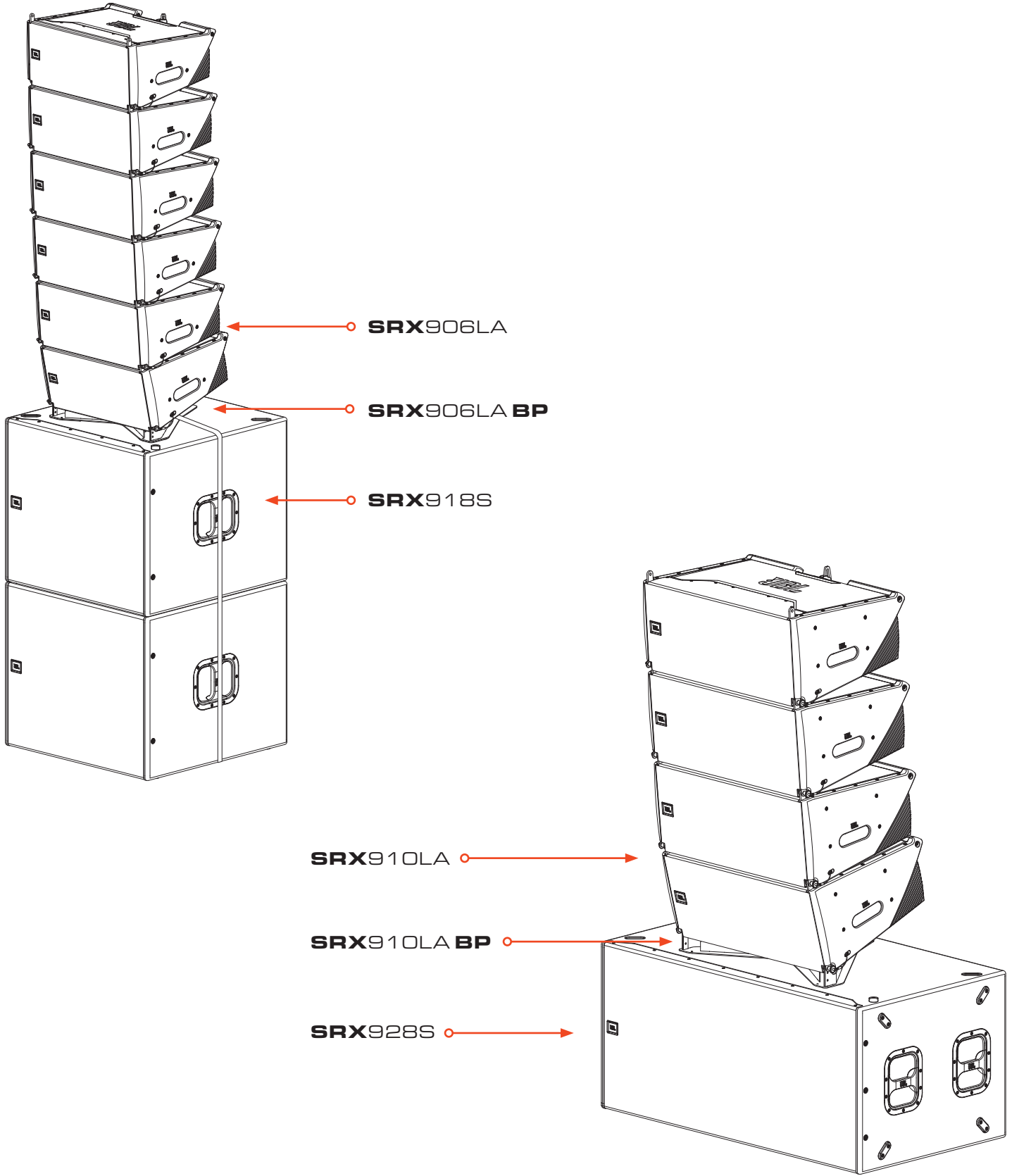

13.6 ATTACHING THE BASE PLATE ONTO A STRUCTURE

The base plate can be permanently attached to a structure like a stage or platform using its three M10 through-holes. This is especially useful for permanent installations or other fixed applications where a ground-stacked SRX9xxLA system is needed, but not often moved. In such situations, the base plate is permanently attached to the structure and subwoofers are not used beneath the array. For detailed drawings of the SRX9xxLA base plates and the position and size of their holes, refer to the **SRX900 BP Customer Drawings**.

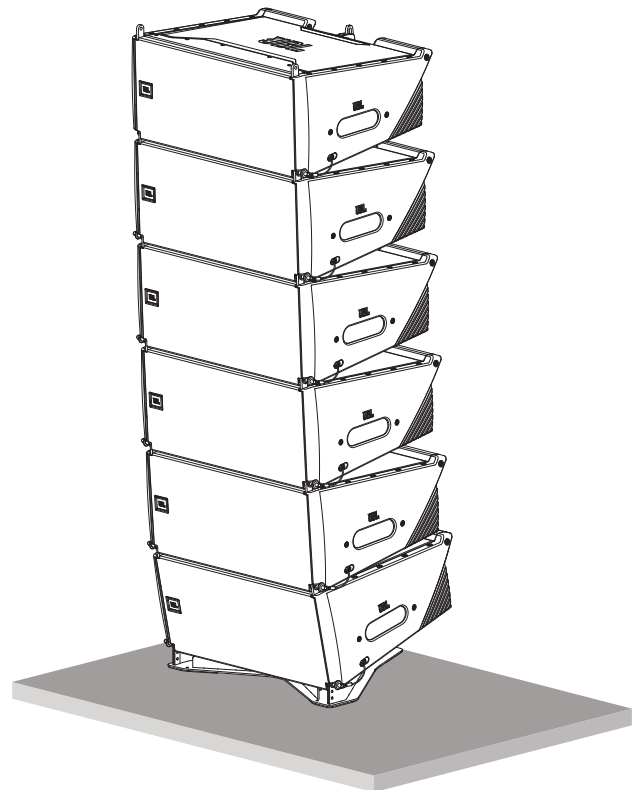
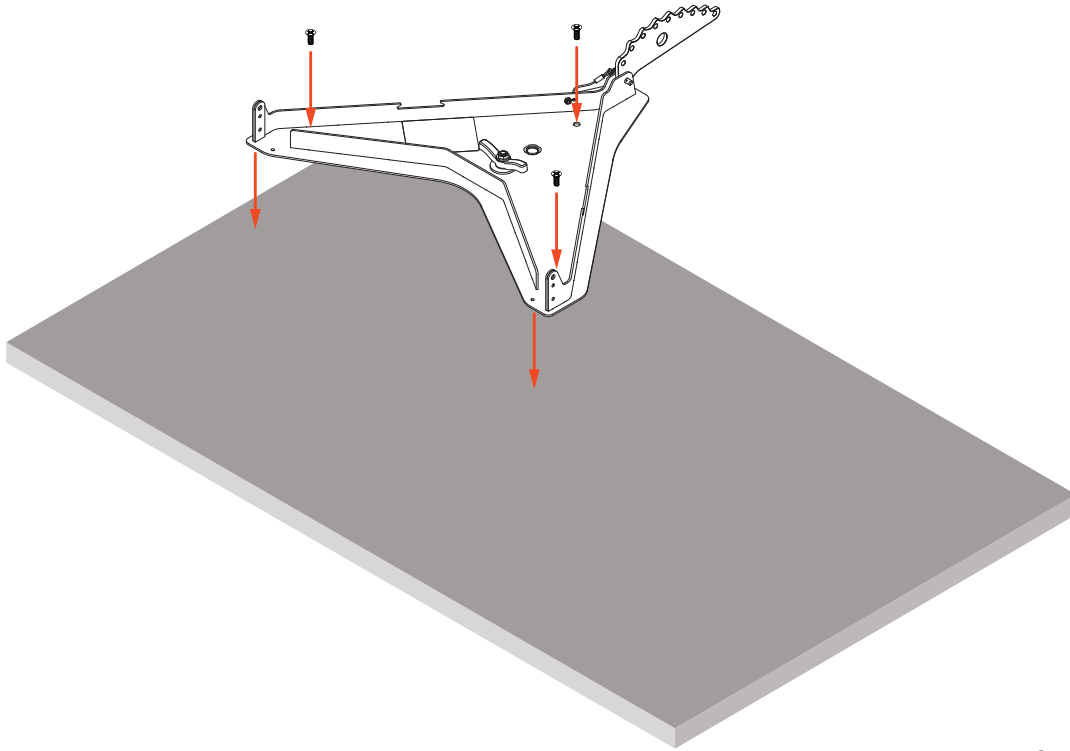

14 - POLE MOUNTING SRX906LA

Using one of two available accessories, SRX906LA cabinets can be mounted on a standard 35mm on top of a compatible SRX900 Series subwoofer or a speaker tripod pole. Pole-mounted SRX906LA systems should sit 1.9 meters (6.2 ft) off the ground, and are designed to work with the SA preset.

14.1 POLE MOUNTING THE SRX906LA BP

When used in conjunction with the VTX PM Pole Mount Adapter the SRX906LA Base Plate accessory can be used for pole mounting SRX906LA speakers. This VTX PM mounts attaches directly to the bottom of the Base Plate using two included thumb screws.

STEPS:

- 1 Mount the VTX PM to the base of the SRX906LA BP using the two included thumb screws.
- 2 Install the completed assembly on top of a compatible pole accessory at a height of 1.9 meters.
- 3 Follow instructions in section 11.4 - **Assembling Ground-Stacked Arrays** to stack up to two SRX906LA cabinets on top of the Base Plate using the angles below.

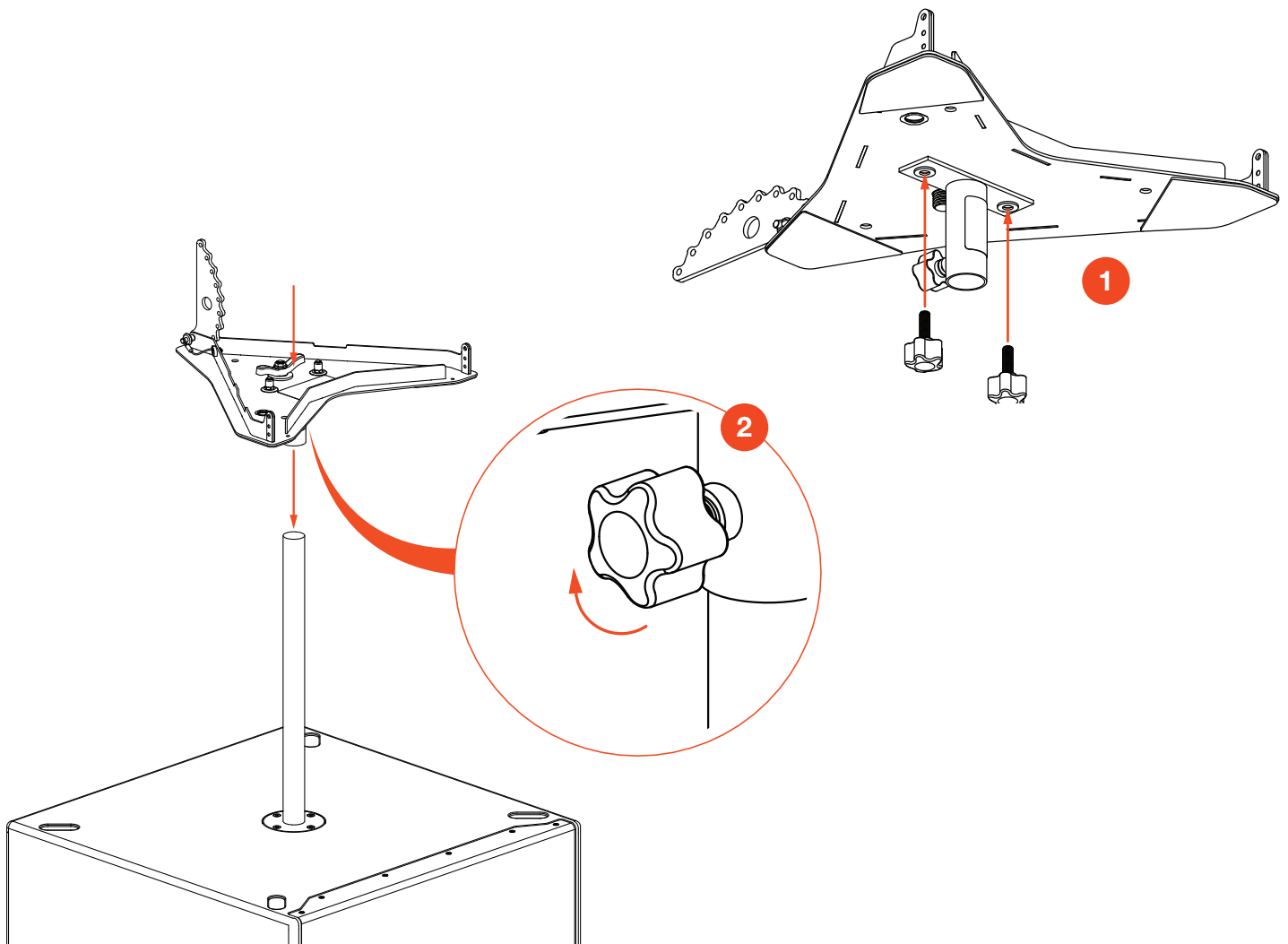

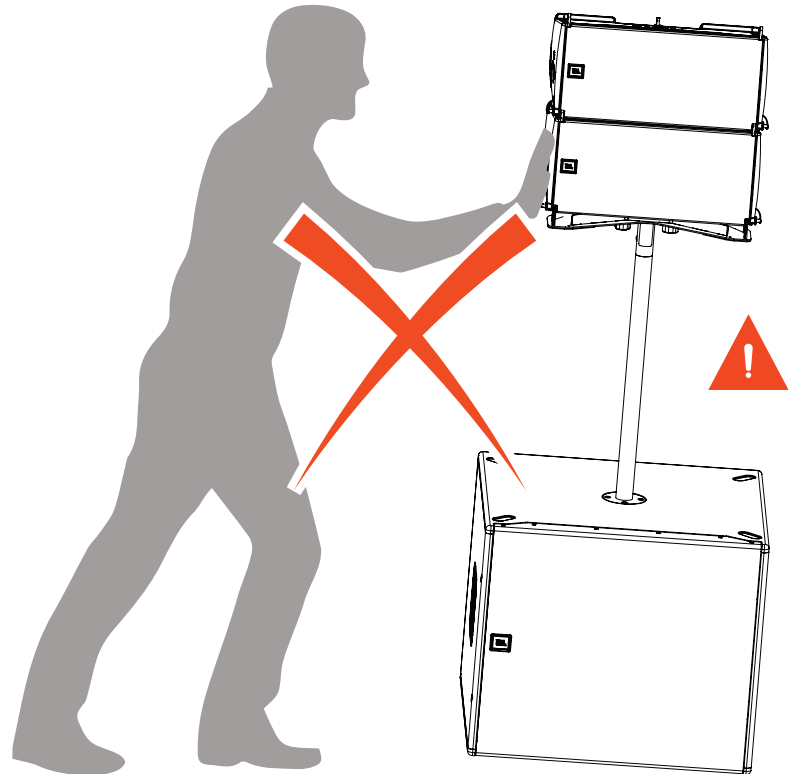
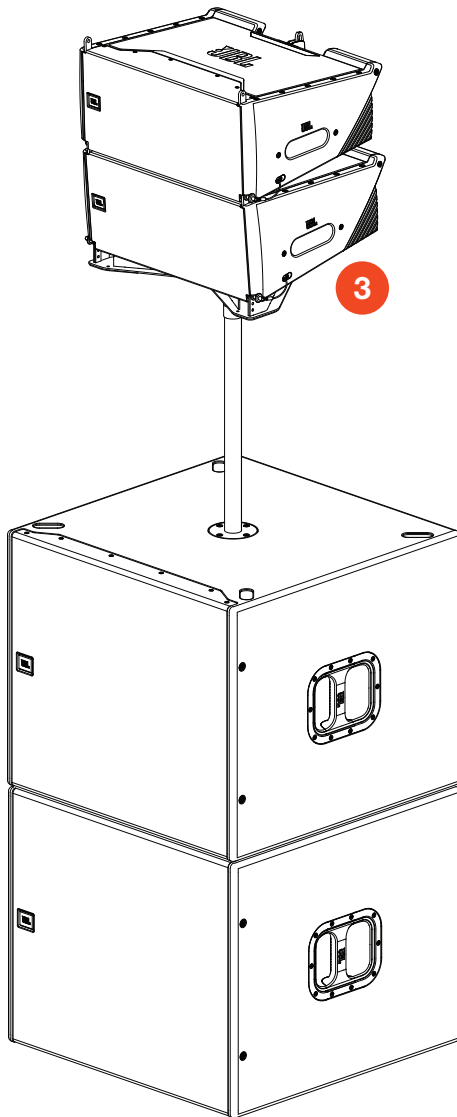

CAUTION: Do not deploy ground-stacked arrays on non-flat surfaces to avoid tipping hazards. Safe limits for ground-stacked arrays always assume that the stacking surface (floor and stage) is flat.



CAUTION: Lifting or pushing the extension rod, or sliding the subwoofer with a loaded extension rod, is unsafe. This can result in permanent damage or reduce the capacity of the M20 plate, potentially leading to a falling loud-speaker and personal injury.

14.2 SRX906LA PM OVERVIEW

The SRX906LA PM is dedicated pole mount only solution that can be used when the ground stacking functionality of the standard SRX-906LA BP is not required. The SRX906LA PM is lighter-weight and requires few components to create a functional pole mounted system than the SRX906LA BP and VTX PM combination but is deployed with similar steps.

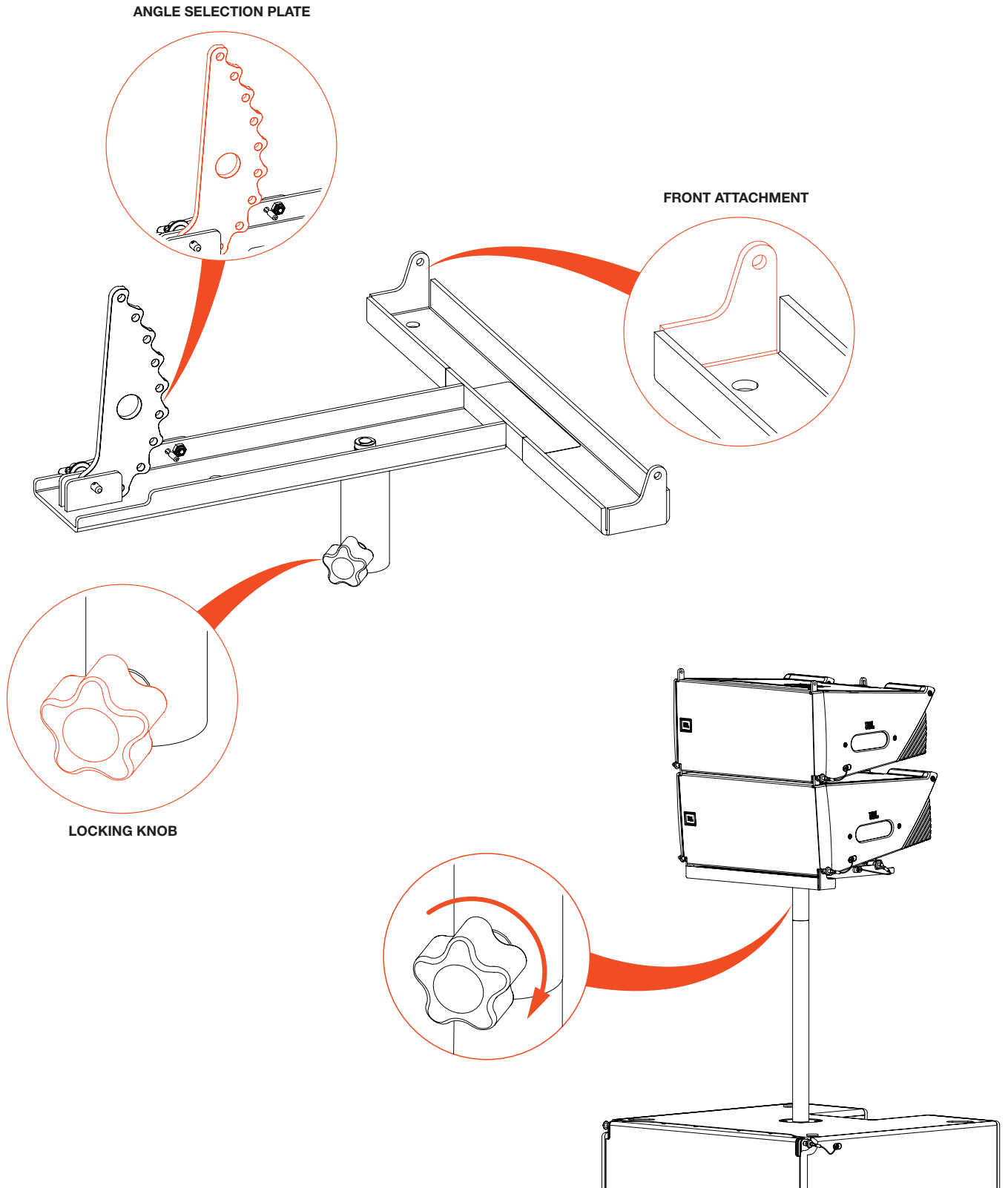

14.3 SRX906LA PM STORAGE POSITION

The angle selection plate can be removed from its normal position and placed in a storage location. The bottom pole receiver is used to secure the angle selection plate onto the base plate.

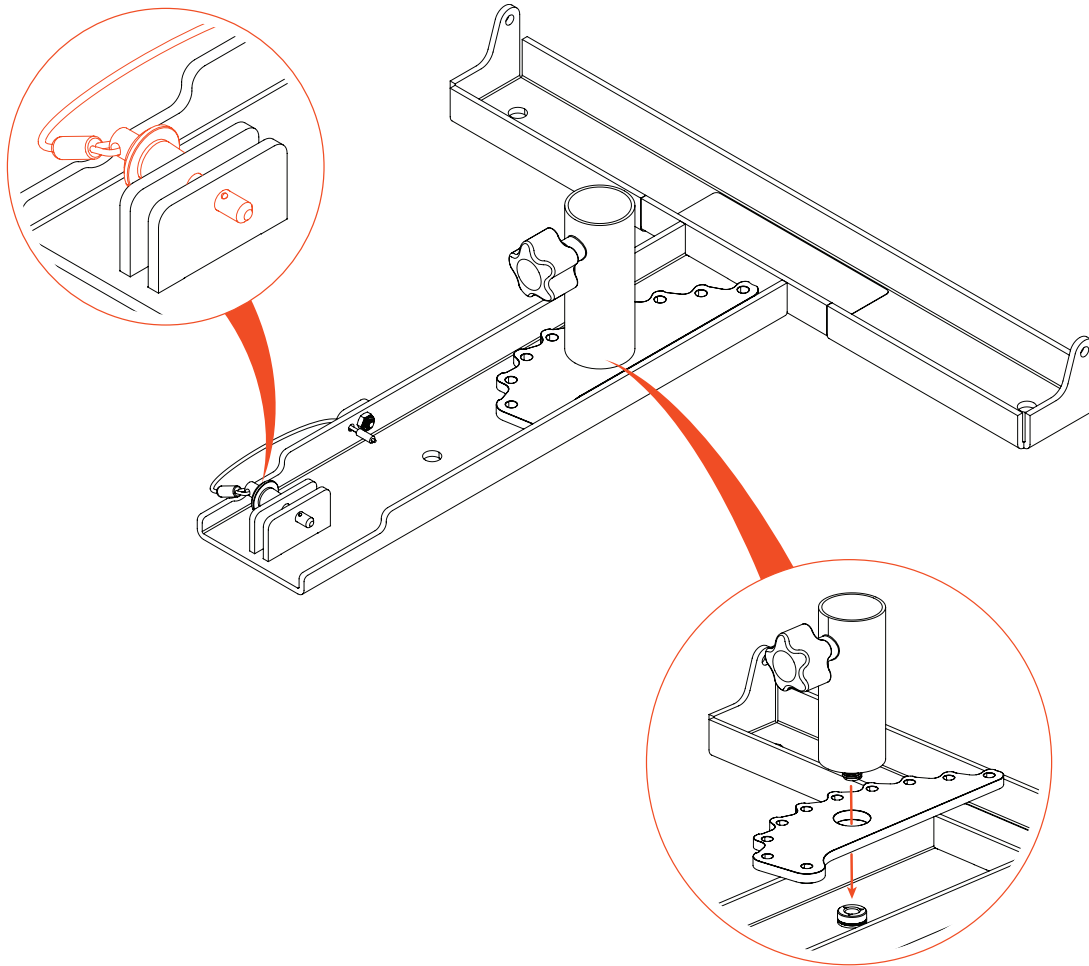

15 - CONTACT INFORMATION

UNITED STATES OF AMERICA

HARMAN Professional Solutions

8500 Balboa Blvd.
Northridge, CA 91329
USA
+1 (844) 776-4899
www.jblpro.com

U.S.A. Technical Support

+1 (844) 776-4899
HProTechSupportUSA@Harman.com
www.jblpro.com

PROFESSIONAL CONTACTS, OUTSIDE THE U.S.A.:

Contact the JBL Professional distributor in your area. A complete list of JBL Professional international distributors is provided at our U.S.A. website: www.jblpro.com

HARMAN Professional EMEA

Westside
London Road
Hemel Hempstead
HP3 9TD
United Kingdom
www.pro.harman.com
www.jblpro.com/support

HARMAN Professional APAC

108 Pasir Panjang Road
#02-08 Golden Agri Plaza
Singapore 118535
+65 6870-5000
www.pro.harman.com
www.jblpro.com/support

HARMAN Professional China

20F, China Merchants Port Plaza, #1
Gongye 3rd Road, Shekou, Nanshan
Dist.
Shenzhen, 518067, China
400 166 7806
www.harman.com/China
www.jblpro.com/support

China In-Country Support

ChinaPRO.Service@harman.com

HARMAN Professional India

Prestige Technology Park
Jupiter 2A Block, 4th Floor
Marathahalli Ring Road
Bangalore 560103, India
+1 (800) 208-8880
www.harman.com/India
www.jblpro.com/support

HARMAN Professional Brazil

Br386, Km435 92480-000
Nova Santa Rita Rs
Brazil
+55 51 34794000
www.harman.com/Brasil
www.jblaudio.com.br
www.jblpro.com/support

India In-Country Support

www.harman.com/india/india-service-center

Brazil In-Country Support

tecnica@harman.com

JBL

PROFESSIONAL